

PK

turbine pumps with
peripheral impeller
end suction



RANGE OF PERFORMANCE

Capacity up to 23 gpm
Head up to 329 ft

LIMITS OF USE

Manometric suction lift up to 26 ft
Liquid temperature up to + 140°F
Environment temperature up to + 104°F

CONSTRUCTION AND SAFETY STANDARDS

EN 60 335-1	EN 60034-1
IEC 335-1	IEC 34-1
CEI 61-150	CEI 2-3



INSTALLATION AND USE

They are recommended for pumping clean water without abrasive particles and liquids that are chemically non aggressive to the materials from which the pump is made.

FOR THEIR RELIABILITY, SIMPLICITY OF USE AND ECONOMY THEY ARE SUITABLE FOR RESIDENTIAL USE AND IN PARTICULAR FOR DISTRIBUTING WATER IN COMBINATION WITH SMALL PRESSURE SETS, FOR IRRIGATING GARDENS.

It is recommended to install the pumps in enclosed places, or at least protected against inclement weather.

GUARANTEE 2 YEAR subject to our general terms of sale.

CONSTRUCTION CHARACTERISTICS

- **PUMP BODY:** cast iron, with threaded ports.
- **MOTOR BRACKET (patent n° 1289150):** aluminium with brass insert; reduces starting difficulties due to seizure of the impeller after long periods of inactivity.
- **IMPELLER:** brass, of the type with radial peripheral vanes.
- **MOTOR SHAFT:** stainless steel EN 10088-3- 1.4104.
- **MECHANICAL SEAL:** ceramic - graphite - NBR.
- **ELECTRIC MOTOR:** the pumps are close-coupled to a carefully matched PEDROLLO electric motor, quiet running, totally enclosed fan cooled (TEFC), suitable for continuous duty.
PK: single-phase 115 V or 230 V - 60Hz with capacitor and thermal overload protector.
PK: three-phase 230/460 V - 60 Hz.
- **INSULATION:** class F. • **PROTECTION:** IP 44.

• REGISTERED MODEL n° 72753.

OPTIONS ON REQUEST

- special mechanical seal
- other voltages or frequency 50 Hz

 **PEDROLLO**
... the spring of life

 tech.support (954) 474 9090

 www.pedrollousa.com

 customerservice@pedrollousa.com

CURVES AND PERFORMANCE DATA

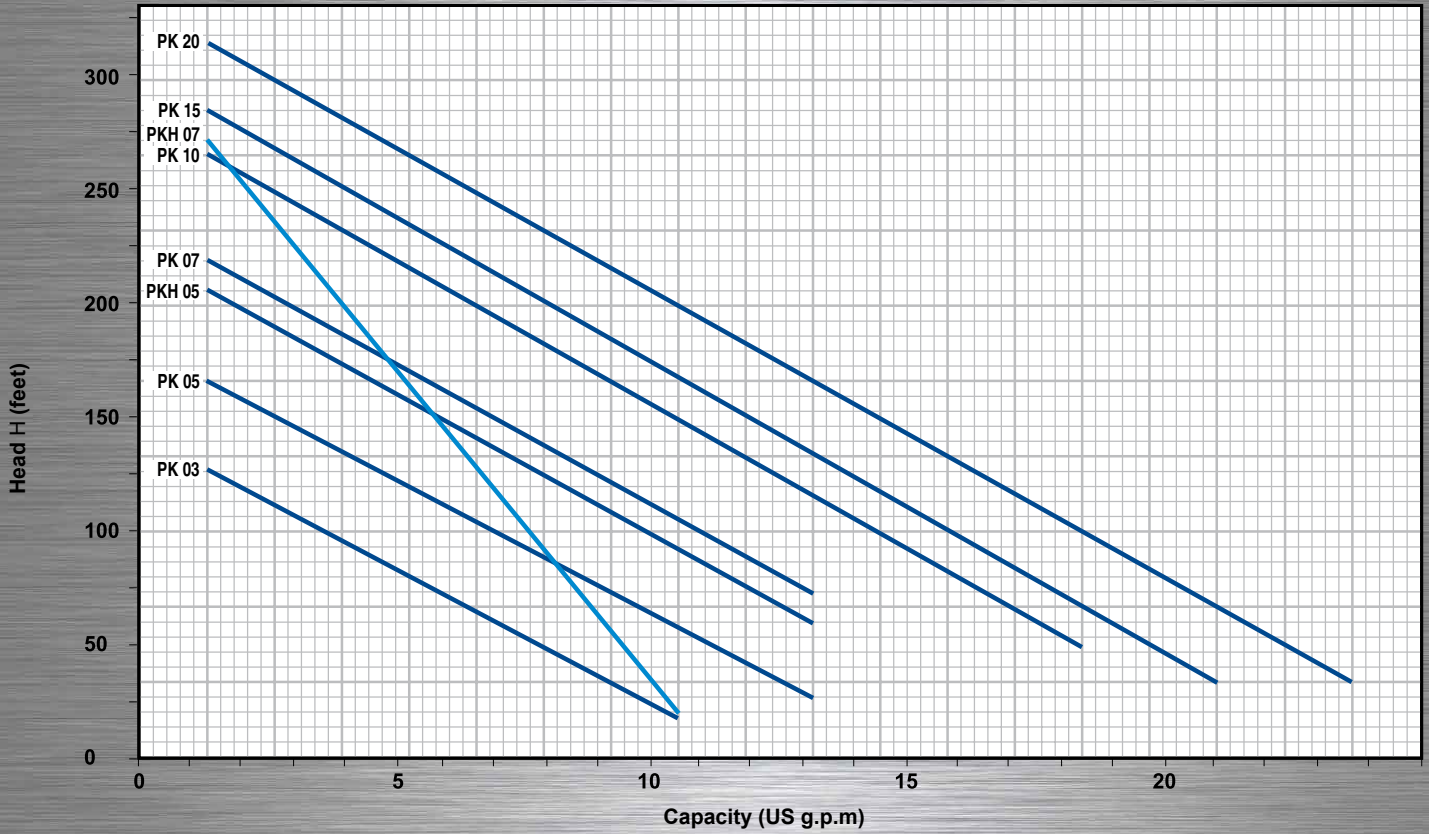

MODEL		HP	CAPACITY GPM	H Feet															
1 PH	3PH			0	1.2	2.7	4	5.5	6.6	8	9.3	10.2	13.2	15	18	21	23		
PK 03	PK 03	0.33		131	124	110	95	78	64	49	32	16							
PK 05	PK 05	0.5		181	164	149	133	118	101	88	72	55	26						
PKH 05	PKH 05	0.5		214	203	187	170	154	137	121	105	88	59						
PK 07	PK 07	0.7		230	216	200	183	167	151	134	119	101	72						
PKH 07	PKH 07	0.7		296	269	233	197	160	124	88	55	16							
PK 10	PK 10	1		279	262	246	229	213	197	180	164	147	114	82	49				
PK 15	PK 15	1.5		296	282	266	249	233	215	197	180	164	131	98	65	32			
	PK 20	2		329	312	295	279	262	246	229	213	197	164	131	98	65	32		

DIMENSIONS AND WEIGHTS

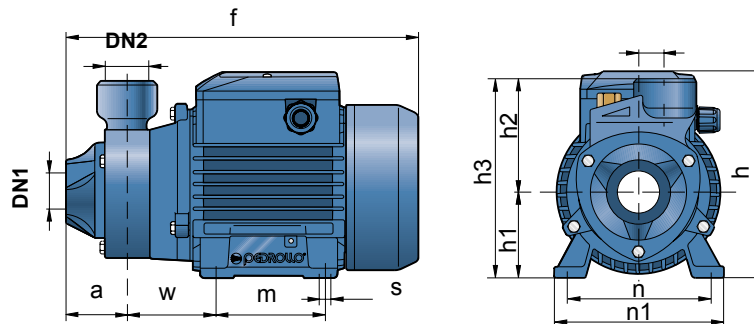

MODEL		DISCH		DIMENSIONS INCHES											LBS		
1 PH	3PH	DN1	DN2	a	f	h	h1	h2	h3	i	m	n	n1	w	s	1~	3~
PK 03	PK 03	1"	1"	1.7	9.5	5.9	2.4	2.9	5.4	0.7	3.1	4.7	3.9	2.1	0.2	11.7	11.7
PK 05	PK 05	1"	1"	1.9	10,15/9,84	5.9	2.4	3.1	5.6		3.1	4.7	3.9	2.1	0.2	17.0	14.1
PKH 05	PKH 05	1"	1"	2.2	11.2	7.0	2.8	3.3	6.1		3.5	5.4	4.4	2.4	0.2	22.3	20.3
PK 07	PK 07	1"	1"	2.2	11.2	7.0	2.8	3.3	6.1		3.5	5.4	4.4	2.4	0.2	22.7	21.8
PKH 07	PKH 07	3/4"	3/4"	2.3	11.3	7.0	2.8	3.7	6.5		3.5	5.4	4.4	2.4	0.2	22.7	20.5
PK 10	PK 10	1"	1"	2.2	13.7	8.3	3.1	3.7	6.8		3.9	6.2	4.9	3.3	0.3	33.1	28.9
PK 15	PK 15	1"	1"	2.2	13.7	8.3	3.1	3.7	6.8		3.9	6.2	4.9	3.3	0.3	35.3	33.5
	PK 20	1"	1"	2.2	13.7	8.3	3.1	3.7	6.8		3.9	6.2	4.9	3.3	0.3		39.7