



CRI20

Parts List & Kits

Contents

Parts List
Spare Part Kits
Accessories
Special Tools
Standard Tools
Tools for Torques

Exploded View **CR120**

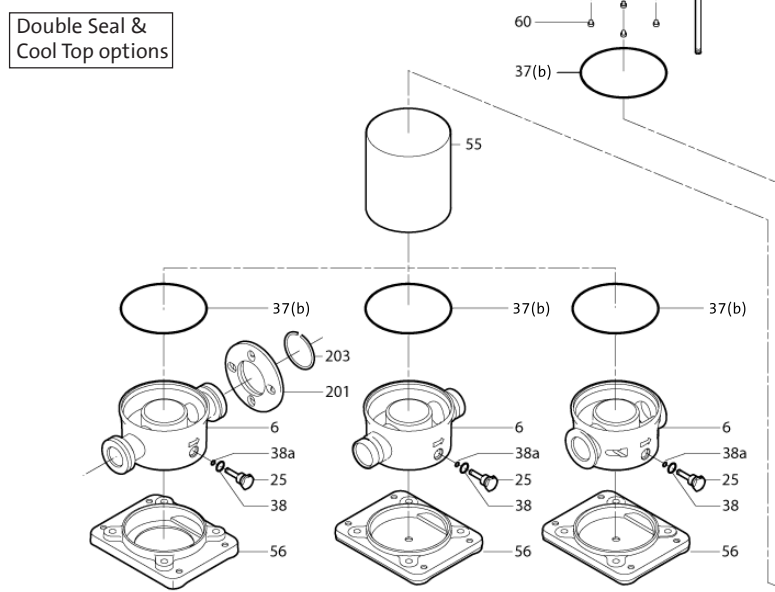
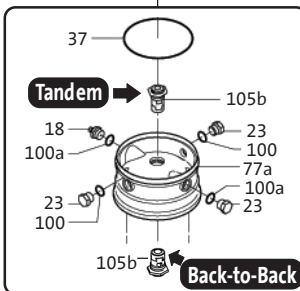
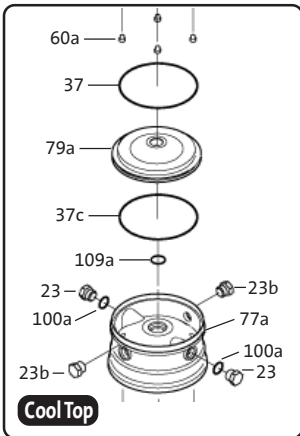
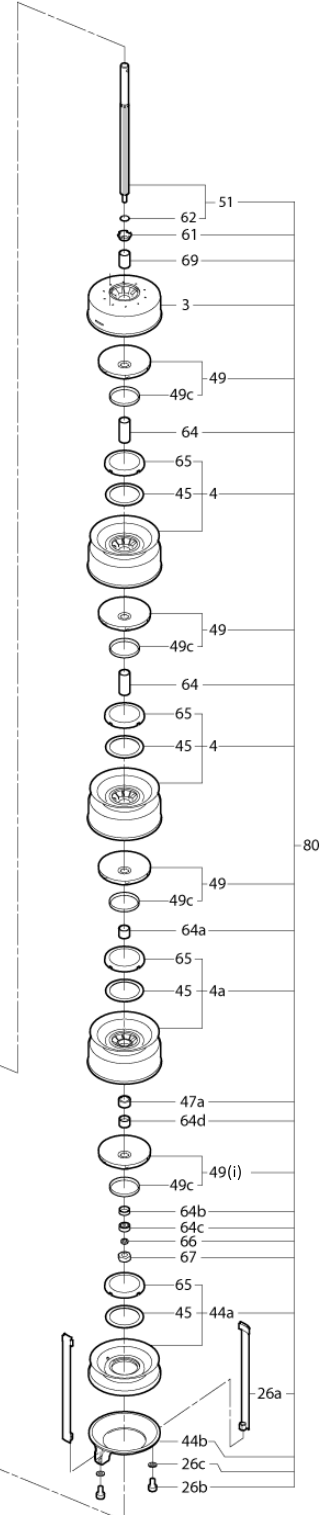
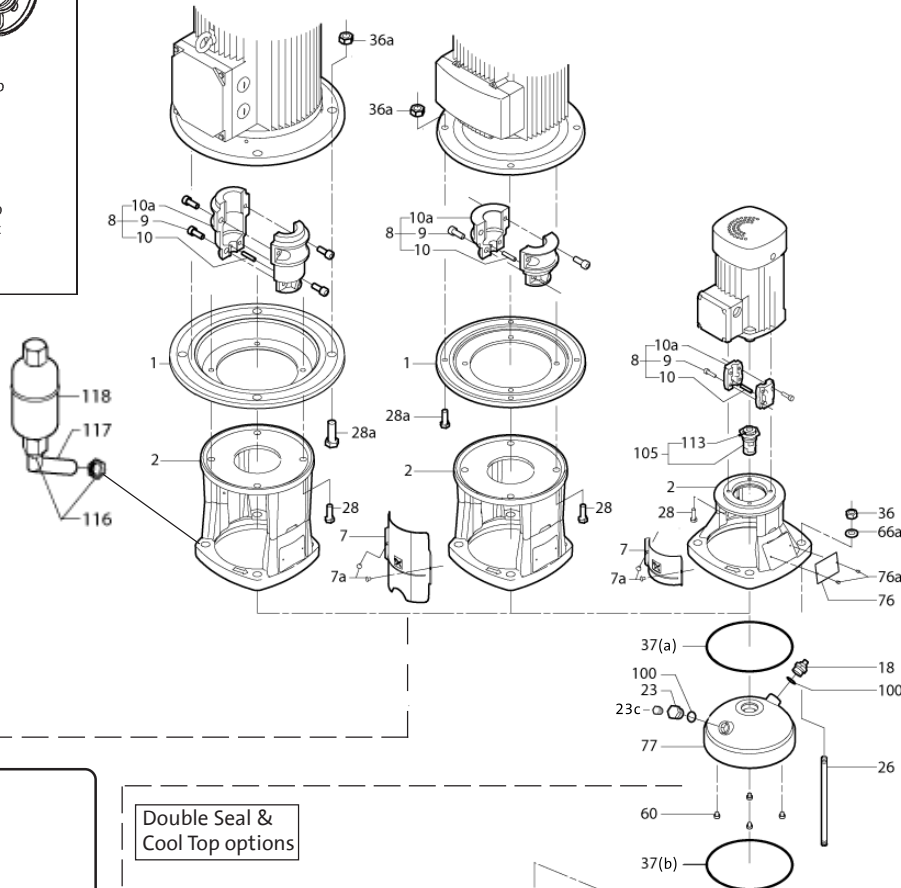
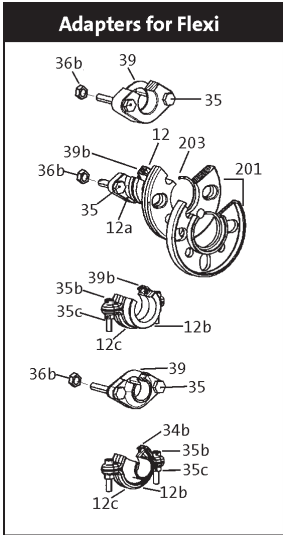

Parts List & Kits **CRI20**

Pos. No.	Part Description	Model	Stages	No. Used	Comments/Dimensions	B.O.M. Ref. No.	Material No.	Included in kits ?
----------	------------------	-------	--------	----------	---------------------	-----------------	--------------	--------------------

PARTS LIST

1	Adapter for Motor Stool		3-4 5-8 4-7 8-17	1 1 1 1	For NEMA, 213/215TC, 7.5 - 10HP For NEMA, F254TC, 15 - 20HP For IEC, F265, MG132, 5.5 - 7.5kW For IEC, F300, MG160, 8.0 - 18.5kW	96476208 96486329 96486323 96486326		No No No No
2	Motor Stool Cat. Cast Iron, without insert pos. 77		2/1-3 2/1-3 3-4 3-4 5-8 10 1 2/1 2 3 4-7 8-17	1 1 1 1 1 1 1 1 1 1 1 1	NEMA, 56C, .75 - 2.0HP NEMA, 182TC, Low, 3 - 5Hp NEMA, 182TC, High, 3 - 5Hp (option) Add pos. 1 for NEMA 213/215TC, 7.5-10HP Add pos. 1 NEMA 213/215TC, 7.5-10HP (High opt.) Add pos. 1 for NEMA, 254/256TC, 15-20HP NEMA, 284/286TSC, 25HP IEC, F85, MG 71, .37 - .55kW IEC, F100, MG 80, .75 - 1.1kW IEC, F115, MG 90, 1.5 - 2.2kW IEC, F130, MG 100/112, 3.0 - 4.0 kW Add pos. 1 for IEC, F265, MG132, 5.5 - 7.5kW Add pos. 1 for IEC, F300, MG160, 8.0 - 18.5kW	96486290 96486308 96486314 96486308 96486314 96486314 96486296 96486266 96486272 96486278 96486284 96486308 96486314		No No No No No No No No No No No No
3	Chamber, Top, complete with guide vane		2-17	*1	Slotted to accept Strap, pos. 26a	96487786		No
3a	Chamber, Top, without guide vane		2/1	*1	Slotted to accept Strap, pos. 26a	96491222		No
3b	Chamber without guide vane		3-17	*1		330015		No
4	Chamber complete w/guide vane and pos. 45 & 65		3-17	***	PTFE pos. 45	96475765		No
4a	Chamber N Cpl. w/pos. 45 & 65 & Bearing		2/1-17	****	Silicon Carbide Brg, PTFE pos. 45	96475768		YES
	Chamber N Cpl. w/pos. 45 & 65 & Brg. (option)		2/1-17	****	Graflon Bearing, PTFE pos. 45	96492510		YES
	Chamber N Cpl. w/pos. 45 & 65 & Brg. (option)		2/1-17	****	Bronze Bearing, PTFE pos. 45	96492512		YES
6	Base		2/1-5 2/1-17 2/1-17	1 1 1	Flexi -Clamp/Oval, SS. (max. 232 PSI), 50Hz to 7 stg. For DN50 Flanges JIS, FGJ, ANSI, SS (max. 362 PSI) Victaulic (PJE) 2", Stainless (max. 362 PSI)	96490789 96490704 96490828		No No No
7	Coupling Guard		2/1:50Hz 2:50Hz 2/1-4 2/1-17	2 2 2 2	IEC, F85-F100 NEMA-56C, IEC-F115,130 NEMA, 182-215TC (Low); IEC F115 - 265 to 7 stage NEMA, 182-215TC (High),254TC-286TSC, IEC F300	96491001 96491002 96490657 96490656		YES YES YES YES
7a	Screw for Coupling Guard		1-17	4	Screw comb. slot torx/straight slot 4 x 8mm	96488481		YES
9	Allen Screw			4	M6 x 20mm, Delta Seal	001D7899		YES
			2-3: 50 Hz	4	M8 x 25mm, Delta Sl. use with pos. 10a-480006 & 8	001D7900		YES
10	Shaft Pin		2/1-17	4	M10 x 25mm, Delta Seal	001D7901		YES
10a	Coupling Half (machined set)		2/1-17	1	ø5 x 26mm	310192	95061337	YES
			2/1-2	1	NEMA, 56C, 1/3 - 2HP, ø15.9/ ø16mm	96516777		YES
			2/1-2	1	NEMA, 182/184TC, 3-5HP, ø28.6/ø16mm (Std-Low)	96516774		YES
			3-4	1	NEMA, 182/184TC, 3-5HP, ø28.6/ø16mm (Opt-High)	96516009		YES
			3-4	1	NEMA, 213TC, 7.5-10HP, ø34.9/ø16mm (Std-Low)	96516775		YES
			3-4	1	NEMA, 213TC, 7.5-10HP, ø34.9/ø16mm (Opt-High)	96516770		YES
			5-8	1	NEMA, 254TC, 15-20HP, ø41.2/ø16mm (High)	96516771		YES
			10	1	NEMA, 284/286TSC, 25HP, ø41.2/ø16mm	96516771		YES
	Coupling Half			2	IEC, F85, MG71, .37-.55kW, ø14/ø16mm	480002		YES
			2/1	2	IEC, F100, MG80, .75-1.1kW, ø19/ø16mm	480004		YES
			2	2	IEC, F115, MG 90, 1.5-2.2kW, ø24/ø16mm	480006		YES
			3	2	IEC, F130, MG100/112, 3-4 kW.ø28/ø16mm	480008		YES
	Coupling Half (machined set)		4-7 8-17	1 1	IEC, F265, MG132, 5.5-7.5kW. ø38/ø16mm IEC, F300, MG160, 8.0-18.5kW. ø42/ø16mm	96516772 96516008		YES YES
12	Oval Flange		2/1-5 2/1-5 2/1-5 2/1-5	2 2 2 2	Painted CI, 1-1/2" -11.5 NPT. Option (max. 232 PSI) Stainless, 1-1/2" -11.5 NPT. Option (max. 232 PSI) Painted CI, 2.0" -11.5 NPT (max. 232 PSI) Stainless, 2.0" -11.5 NPT (max. 232 PSI)	96493637 96490775 96493636 96490782		YES YES YES YES
	Oval Flange, 50 Hz. models		2/1-7 2/1-7 2/1-7 2/1-7	2 2 2 2	Painted CI, RP 1-1/2" BSP DIN (max. 232 PSI) Stainless, RP 1-1/2" BSP DIN (max. 232 PSI) Painted CI, RP 2.0" BSP DIN (max. 232 PSI) Stainless, RP 2.0" BSP DIN (max. 232 PSI)	320054 96490773 320045 96490781		No No No No
12a	Adapter Flg. for ANSI pos.201/Flexi Base (option)		2/1-5	2	Stainless, DN50 (max. 232 PSI) 50 Hz. to 7 stage	96491152		YES
12b	Pipe Stub for Clamp/Flexi Base (option)		2/1-5 2/1-5 2/1-5 2/1-5 2/1-7 2/1-7 2/1-7	2 2 2 2 2 2 2	Stainless, Internal 1-1/2" -11.5 NPT (max. 232 PSI) Stainless, Internal 2.0" -11.5 NPT (max. 232 PSI) Stainless, Internal 2-1/2" -11.5 NPT (max. 232 PSI) Stainless, RP 2" (max. 232 PSI) SS. DN50 ø60.3x2.9mm Welding Flg. (max. 232 PSI) Stainless, (max. 232 PSI)	96498795 96498796 96498797 330199 330207 001D7195		YES YES YES No No YES
12c	Clamp for Flexi Base & pos. 12b (option)		2/1-7	2	Stainless, (max. 232 PSI)	001D7195		YES
18	Priming/Vent Plug		2/1-17	*	G 1/2A, NV24 with NV9 x M8 stem	405150	95061351	YES
23	Plug		2/1-17	**	G 1/2A, w/1/4" NPT threaded port, NV24	91120659		YES
	Plug (option)		2/1-17	**	G 1/2A, Solid no port, NV24	370025	95061733	YES
23b	Plug Vented for pos. 77a Cool Top option only		2/1-17	2	G 1/2A, Vented, NV25	96510323		No
23c	Pipe Plug for pos. 23 & 25 with hollow stem		2/1-17	**	1/4" NPT, SS SQHD	001D7216		YES
25	Drain Plug without O-rings		2/1-17	1	G 1/2A, NV24 with solid stem	96491043	95061431	YES
	Drain/Priming Plug Cpl. w/O-rings, opt. for gauge		2/1-17	1	G 1/2A, NV24 w/NV9 x M8 hollow stem, EPDM	96528428		No
			2/1-17	1	G 1/2A, NV24 w/NV9 x M8 hollow stem, FKM	96528429		No
			2/1-17	1	G 1/2A, NV24 w/NV9 x M8 hollow stem, FXM	96528431		No
			2/1-17	1	G 1/2A, NV24 w/NV9 x M8 hollow stem, FFKM	96528430		No

Due to part changes over time, all position numbers (1-203) may not be used.

This column indicates which pump model uses the spare part. If blank, the part is used in all models.

Parts List & Kits **CR120**

Pos. No.	Part Description	Model	Stages	No. Used	Comments/Dimensions	B.O.M. Ref. No.	Material No.	Included in kits ?			
PARTS LIST											
26	Staybolt		2/1-2	4	M16 x 270mm	96492803		No			
			3	4	M16 x 315mm	96492805		No			
			4	4	M16 x 360mm	96492807		No			
			5	4	M16 x 405mm	96492809		No			
			6	4	M16 x 450mm	96492851		No			
			7	4	M16 x 495mm	96492853		No			
			8	4	M16 x 540mm	96492854		No			
			10	4	M16 x 630mm	96492857		No			
			12	4	M16 x 720mm, 50 Hz	96492859		No			
			14	4	M16 x 810mm, 50 Hz	96492861		No			
			17	4	M16 x 945mm, 50 Hz	96492863		No			
			26a	Strap		2/1-2	2	L* = 93.5mm x 20.3mm x 1.3mm, 316 SS, M8 nut	96487759		No
						3	2	L* = 138.5mm x 20.3mm x 1.3mm, 316 SS, M8 nut	96487761		No
						4	2	L* = 183.5mm x 20.3mm x 1.3mm, 316 SS, M8 nut	96487763		No
						5	2	L* = 228.5mm x 20.3mm x 1.3mm, 316 SS, M8 nut	96487765		No
						6	2	L* = 273.5mm x 20.3mm x 1.3mm, 316 SS, M8 nut	96487767		No
						7	2	L* = 318.5mm x 20.3mm x 1.3mm, 316 SS, M8 nut	96487769		No
8	2	L* = 363.5mm x 20.3mm x 1.3mm, 316 SS, M8 nut				96487770		No			
10	2	L* = 453.5mm x 20.3mm x 1.3mm, 316 SS, M8 nut				96487774		No			
12: 50 Hz.	2	L* = 543.5mm x 20.3mm x 1.3mm, 316 SS, M8 nut				96487776		No			
14: 50 Hz.	2	L* = 633.5mm x 20.3mm x 1.3mm, 316 SS, M8 nut				96487780		No			
17: 50 Hz.	2	L* = 768.5mm x 20.3mm x 1.3mm, 316 SS, M8 nut	96487782		No						
26b	Bolt for pos. 26a		2/1-17	2	M8 x 25mm, 316 SS w/Delta Seal	96416603		No			
26c	Washer for pos. 26b		2/1-17	2	A4, ϕ 16.0/ ϕ 8.4x1.6mm	00ID3284		No			
28	Motor Bolt		2/1	4	NEMA, 56C, 1/3 - 2HP. UNC 3/8" x 25mm	00ID1839		No			
			3-4	4	NEMA, 182/184TC, 3 - 5HP. UNC 1/2" x 25mm	00ID1840		No			
			5-8	4	NEMA, 213TC, 7.5 -10HP. JR 1/2" x 1.25" UNC	00ID0185		No			
			10	4	NEMA, 254TC, 15-20HP. 1/2" x 2.5" UNC	96491112		No			
				4	NEMA, 284TC, 25HP. UNC 1/2" x 25mm	00ID1840		No			
			2/1	4	IEC, F85, MG71, .37-55kW. M6 x 20mm	00ID8022		No			
			2	4	IEC, F100, MG80, .75-1.1kW. M6 x 25mm	00ID8023		No			
			3	4	IEC, F115, MG 90, 1.5-2.2kW. M8 x 20mm	00ID8024		No			
			4-7	4	IEC, F130, MG100/112, 3-4 kW. M8 x 25mm	00ID8025		No			
			8-17	4	IEC, F265, MG132, 5.5-7.5kW. M12 x 25mm	00ID7915		No			
28a	Motor Bolt		4-7	4	IEC, F300, MG160, 8.0 - 18.5kW. M12 x 25mm	00ID7915		No			
			8-17	4	IEC, F265, MG132, 5.5-7.5kW. M12 x 30mm	00ID7904		No			
			8-17	4	IEC, F300, MG160, 8.0 - 18.5kW. M16 x 45mm	00ID7905		No			
35	Hexagon Head Screw for SS 2" Oval Flange		2/1-5	4	M12x80mm ISO 4014	00ID9241		YES			
	Hexagon Head Screw for Cast Iron Oval Flg.		2/1/-5	4	M12 x 90mm, 8.8 DIN931	96502505		YES			
35b	Screw for Clamp Pos.12c (Flexi option)		2/1-5	4	M10 x 45mm	00ID7189		YES			
35c	Nut for Screw pos. 35b for Clamp Pos.12c (Flexi opt.)		2/1-5	4	Nut RR M10	00ID3570		YES			
36	Staybolt Nut		2/1-17	4	24mm x M16, Delta Seal	00ID7908		No			
36a	Nut for motor bolt IEC MG 160 models		8-17	4	24mm x M16, Delta Seal	00ID7908		No			
36b	Nut for flange Hex. Screw pos. 35		2/1-5	4	19mm x M12, 50 Hz to 7 stage	96550564		YES			
			2/1-5	4	19mm x M12, 316 SS., 50 Hz to 7 stage	00ID0876		No			
			2/1-5	4	19mm x M12, Delta Seal, 50 Hz to 7 stage	00ID7917		YES			
37(a)	Sleeve O-ring		2/1-17	◆◆	EPDM, ϕ 170.7 x 3.3mm	96483101		YES			
			2/1-17	◆◆	FKM, ϕ 170.7 x 3.3mm	96483102		YES			
37b	Sleeve O-ring (option)		2/1-17	◆◆	FKM, ϕ 171.25 x 3.3mm	96483109		YES			
			2/1-17	◆◆	FFKM, ϕ 170.7 x 3.3mm	96483140		YES			
37c	Disc plate O-ring (Cool Top option only)		2/1-17	1	EPDM, ϕ 155.0 x 3.0mm	96509703		YES			
			2/1-17	1	FKM, ϕ 155.0 x 3.0mm	96480168		YES			
38	Drain Plug O-ring		2/1-17	1	EPDM, ϕ 16.3 x 2.4mm	00ID1288		YES			
			2/1-17	1	FKM, ϕ 16.3 x 2.4mm	00ID2231		YES			
			2/1-17	1	FKM, ϕ 16.3 x 2.4mm	96442869		YES			
			2/1-17	1	FFKM, ϕ 16.3 x 2.4mm	96428162		YES			
			2/1-17	1	ϕ 5.3 x 2.4mm, EPDM	00ID2142		YES			
			2/1-17	1	ϕ 5.3 x 2.4mm, FKM	00ID3945		YES			
			2/1-17	1	ϕ 5.3 x 2.4mm, FKM, black	96511292		YES			
38a	Drain Plug O-Ring		2/1-17	1	ϕ 5.3 x 2.4mm, FFKM	96511293		YES			
			2/1-17	1	ϕ 5.3 x 2.4mm, FFKM	96511293		YES			
39	Gasket for Oval Flange		2/1-5	2	K, 124mm x ϕ 80/ ϕ 59 x 2mm, 50 to 7 stage	320120		YES			
			2/1-5	2	K, 122mm x ϕ 60/ ϕ 44 x 2mm (use with 1-1/2" flg.)	420039		YES			
39b	O-ring for Flexi Clamp FGJ Flange (option)		2/1-5	2	EPDM, ϕ 64.5 x 3mm, 50 Hz to 7 stage	00ID2143		YES			
			2/1-5	2	FKM, ϕ 64.5 x 3mm, 50 Hz to 7 stage	00ID4038		YES			
			2/1-5	2	EPDM, ϕ 71.0 x 4mm, 50 Hz to 7 stage	00ID7192		YES			
			2/1-5	2	FKM, ϕ 71.0 x 4mm, 50 Hz to 7 stage	00ID7193		YES			

Due to part changes over time, all position numbers (1-203) may not be used.

This column indicates which pump model uses the spare part. If blank, the part is used in all models.

Parts List & Kits CRI20

Pos. No.	Part Description	Model	Stages	No. Used	Comments/Dimensions	B.O.M. Ref. No.	Material No.	Included in kits ?
----------	------------------	-------	--------	----------	---------------------	-----------------	--------------	--------------------

PARTS LIST

44a	Inlet upper with pos. 45 & 65		2/1-17	1		96489038		No
44c	Inlet upper with pos. 45 & 65 (low NPSH option)		2-17	1		96491227		No
44b	Inlet lower, machined		2/1-17	1		96488000		No
45	Neck Ring		2/1-17	# imp.-	Ø75.8 x Ø59.95 x 1.5mm, PTFE-Acoflon 100	96487400		YES
	Neck Ring (low NPSH option)		2/1-17	1	Ø88.0 x Ø66.2 x 2.2mm, PTFE-Acoflon 215	290091		YES
47a	Bearing Ring/Spacer		2/1-17	^^^^	SiC 150, Ø23.4 x Ø17.6 x Ø15.0 x 14mm	96482117		YES
	Brg. Ring/Spacer (option for Graflon / Brz. 4a)		2/1-17	^^^^	TC, Ø21.9 x Ø17.6 x Ø15.0 x 14mm	330085	95061371	YES
49	Impeller		2/1-17	# stgs-	Ø104.8 x Ø59.85 x 25.4mm (back-plate 1.5mm)	96476526		No
49c	Wear Ring for Impeller 49		2/1-17	# stgs-	Ø59.85 x 7.4mm	330054		YES
49c	Wear Ring for low NPSH Impeller 49i		2/1-17	1	Ø66.0 x 8.5mm	290049		No
49i	Impeller (low NPSH option)		2-17	1	Ø118.8 x Ø66.0 x 32.2mm	96521444		No
51	Shaft, Complete		2/1-2	1	Ø16 x 209.0mm, 431 SS	96490794		No
			3	1	Ø16 x 249.0mm, 431 SS	96490798		No
			4	1	Ø16 x 299.0mm, 431 SS	96490872		No
			5	1	Ø16 x 339.0mm, 431 SS	96490876		No
			6	1	Ø16 x 389.0mm, 431 SS	96490880		No
			7	1	Ø16 x 429.0mm, 431 SS	96490884		No
			8	1	Ø16 x 479.0mm, 431 SS	96490886		No
			10	1	Ø16 x 564.0mm, 431 SS	96490892		No
			12	1	Ø16 x 659.0mm, 431 SS, 50 Hz	96490896		No
			14	1	Ø16 x 744.0mm, 431 SS, 50 Hz	96490910		No
			17	1	Ø16 x 879.0mm, 431 SS, 50 Hz	96490915		No
	Shaft, Cpl. (Back-to-Back, Tandem Seal & Cool Top opt.)		2/1-2	1	Ø16 x 299.0mm, 329 SS	96507538		No
			3	1	Ø16 x 339.0mm, 329 SS	96507570		No
			4	1	Ø16 x 389.0mm, 329 SS	96507572		No
			5	1	Ø16 x 429.0mm, 329 SS	96507574		No
			6	1	Ø16 x 479.0mm, 329 SS	96507576		No
			7	1	Ø16 x 519.0mm, 329 SS	96507578		No
			8	1	Ø16 x 569.0mm, 329 SS	96507579		No
			10	1	Ø16 x 654.0mm, 329 SS	96507582		No
			12	1	Ø16 x 749.0mm, 329 SS, 50 Hz	96507584		No
			12	1	Ø16 x 777.0mm, 329 SS (low NPSH option), 50 Hz	96551867		No
			14	1	Ø16 x 834.0mm, 329 SS, 50 Hz	96507586		No
			17	1	Ø16 x 969.0mm, 329 SS, 50Hz	96507588		No
			17	1	Ø16 x 1014.0mm, 329 SS (low NPSH option), 50 Hz	96529710		No
55	Outer Sleeve		2/1-2	1	Ø171.1/ Ø170.7 x 104.0mm x 1.5mm, 304 SS	96489762		No
			3	1	Ø171.1/ Ø170.7 x 149.0mm x 1.5mm, 304 SS	96489764		No
			4	1	Ø171.1/ Ø170.7 x 194.0mm x 1.5mm, 304 SS	96489766		No
			5	1	Ø171.1/ Ø170.7 x 239.0mm x 1.5mm, 304 SS	96489767		No
			6	1	Ø171.1/ Ø170.7 x 284.0mm x 1.5mm, 304 SS	96489769		No
			7	1	Ø171.1/ Ø170.7 x 329.0mm x 1.5mm, 304 SS	96489771		No
			8	1	Ø171.1/ Ø170.7 x 374.0mm x 2.0mm, 316 SS	96489829		No
			10	1	Ø171.1/ Ø170.7 x 464.0mm x 2.0mm, 316 SS	96489831		No
			12	1	Ø171.1/ Ø170.7 x 554.0mm x 2.0mm, 316SS, 50 Hz	96489833		No
			14	1	Ø171.1/ Ø170.7 x 644.0mm x 2.0mm, 316SS, 50 Hz	96489835		No
			17	1	Ø171.1/ Ø170.7 x 779.0mm x 2.0mm, 316SS, 50 Hz	96489836		No
56	Base Plate (Low) for PJE / Flexi-clamp pos. 6		2/1-17	1	Cast Iron (used on 50 Hz models)	96493006		No
	B. P. (High) for PJE/Flexi-clamp w/FGJ pos. 6		2/1-17	1	Cast Iron (All 60 Hz.; On 50 Hz FGJ models)	96493003		No
	Base Plate N (Low) for PJE / Flexi-clamp pos. 6	GI	2/1-17	1	Cast Stainless (Used on 50 Hz models)	96490808		No
	B. P. N (High) for PJE/Flexi-clamp w/FGJ pos. 6	GI	2/1-17	1	Cast Stainless (All 60 Hz.; On 50 Hz. FGJ models)	96490806		No
60	Stack Compression Spring		2/1-17	4	Ø11.0 x Ø7.0 x 15.5mm, EPDM	96503070		YES
			2/1-17	4	Ø11.0 x Ø7.0 x 15.5mm, FKM	96503072		YES
60a	Stack Compression Spring (option)		2/1-17	4	Ø11.0 x Ø7.0 x 15.5mm, PTFE	96503071		YES
61	Stop spacer		2/1-17	1	Ø29.0 x Ø18.4 x Ø17.6 x Ø15.0 x 9.5 x 2mm	330072	95061584	YES
62	Stop ring		2/1-17	1	Ø16.6 x Ø15.0 x 1.6mm	330057		YES
64	Spacing Pipe		3-17	^^^	Ø21.5 x Ø17.5 x 43.6mm	331407		No
64a	Spacing Pipe		2-17	^^^^	Ø21.5 x Ø17.5 x 17.0mm	331416		YES
64b	Spacing Pipe		2-17	^^^^^	Ø21.5 x Ø17.5 x 5.0mm	331401		YES
64c	Clamp, Splined		2/1-17	1	Ø21.5 x Ø17.6 x Ø15.0 x 12.7mm	96496311		YES
64d	Spacing Pipe		2/1-17	^^^^^^	Ø21.5 x Ø17.5 x 12.6mm	96491535		YES
64e	Spacing Pipe (low NPSH option only)		2-17	^ +	Ø21.5 x Ø17.5 x 8.0mm	331411		No
64f	Spacing Pipe (low NPSH option only)		2/1	^ -	Ø21.5 x Ø17.5 x 18.0mm	96491536		No
64g	Spacing Pipe (de-staging 2 impellers option only)		3-17	1 per de-stg	Ø21.5 x Ø17.5 x 45.0mm (use with 3b only)	331408		No
65	Neck Ring Retainer		2/1-17	# stgs-	Ø78.8 x Ø61.5 x 6.7mm	330059		YES
	Neck Ring Retainer (low NPSH option)		2-17	1	Ø84.5 x Ø67.8 x 4.6mm	290059		No
66	Lock Washer Set for Shaft		2/1-17	1	Ø13.5 x Ø8.2 x 2.6mm	96417297		YES
66a	Washer for Staybolt		2/1-17	4	DIN 125A, Ø30 x Ø17 x 2.5mm, Delta Seal	96430378		No
67	Lock Nut for Shaft		2/1-17	1	13mm x M8	96496488		YES
69	Spacing Pipe		2-17	⊖	Ø27.5 x Ø17.5 x 27.5mm	96491537		No
69a	Spacing Pipe (de-staging option only)		2/1	1	Ø21.5 x Ø17.5 x 29.05mm (use with 3a only)	331404	95061499	No
76	Nameplate		2/1-17	1	304SS, 60 x 45mm	96563333		No
76a	Rivet for Nameplate		2/1-17	2	304SS, Ø3 x 5mm	96022882		No
77	Pump Head Cover for motor stool pos. 2		2/1-17	1	Cast Stainless	96490647		No
77a	Pump Head Cover for Tandem Seal & Cool Top		2/1-17	1	Cast Stainless	96505487		No
	Pump Head Cover for Back-to-Back		2/1-17	1	Cast Stainless	96505488		No

Due to part changes over time, all position numbers (1-203) may not be used.

This column indicates which pump model uses the spare part. If blank, the part is used in all models.

Parts List & Kits **CR120**

Pos. No.	Part Description	Model	Stages	No. Used	Comments/Dimensions	B.O.M. Ref. No.	Material No.	Included in kits ?
PARTS LIST								
79a	Disc / Plate complete w/79b & c for Cool Top		2/1-17	1	Cast Stainless	96511281		No
79b	Bushing for Disc / Plate 79a		2/1-17	1	Graflon	96505571		No
79c	Retaining Ring for 79b		2/1-17	1	Stainless	96510985		No
100	Priming/Vent Plug O-ring		2/1-17	■	EPDM, ø16.3 x 2.4mm	00ID1288		YES
			2/1-17	■	FKM, ø16.3 x 2.4mm	00ID2231		YES
100a	Priming/Vent Plug O-ring (option)		2/1-17	■	FFKM, ø16.3 x 2.4mm	96428162		YES
	Priming/Vent Plug O-ring (option)		2/1-17	■	FXM, ø16.3 x 2.4mm	96442869		YES
105(b)	Shaft Seal HQBE		2/1-17	***	SiC, Carbon with resin-impregnated, EPDM	96484076		YES
	Shaft Seal HQBV		2/1-17	***	SiC, Carbon with resin-impregnated, FKM	96484077		YES
	Shaft Seal HQQE		2/1-17	***	SiC, SiC, EPDM	96484071		YES
	Shaft Seal HQQV		2/1-17	***	SiC, SiC, FKM	96484072		YES
	Shaft Seal HQQF (option)		2/1-17	***	SiC, SiC, FXM	96484075		YES
	Shaft Seal HQQK (option)		2/1-17	***	SiC, SiC, FFKM	96484074		YES
	Shaft Seal HUBE		2/1-17	***	TC, Carbon with resin-impregnated, EPDM	96483952		YES
	Shaft Seal HUBV		2/1-17	***	TC, Carbon with resin-impregnated, FKM	96483964		YES
	Shaft Seal HUBF (option)		2/1-17	***	TC, Carbon with resin-impregnated, FXM	96483966		YES
	Shaft Seal HUBK (option)		2/1-17	***	TC, Carbon with resin-impregnated, FFKM	96483965		YES
	Shaft Seal HUUE		2/1-17	***	TC, TC, EPDM	96483967		YES
	Shaft Seal HUUU		2/1-17	***	TC, TC, FKM	96483968		YES
	Shaft Seal HUUF (option)		2/1-17	***	TC, TC, FXM	96484070		YES
	Shaft Seal HUUK (option)		2/1-17	***	TC, TC, FFKM	96483969		YES
109a	O-ring for Disk Plate 79a (Cool Top option only)		2/1-17	1	ø27.2 x 2.75mm, EPDM	96483103		YES
			2/1-17	1	ø27.2 x 2.75mm, FKM	96483104		YES
			2/1-17	1	ø27.2 x 2.75mm, FXM	96483141		YES
116	Counter Nut for Pipe 117		2/1-17	2	NV24, internal G1/2, 316SS	96506709		YES
117	Air Vent Pipe for 118		2/1-6	1	G1/2, 316SS, 56C-213TC .33-10HP; .37 to 7.5 kW	330272		YES
			7-12	1	G1/2, 254TC - 286TSC 15-25HP., 11.0 to 18.5kW	96521537		YES
118	Air Vent		2/1-17	1	Air vent type 1511-AV - 5/6430	96427483		YES
201	Flange, FGJ		2/1-17	2	ANSI, DIN, JIS. DN50 Cast Iron GGG50	96476189		YES
			2/1-17	2	ANSI, DIN, JIS. DN50 Stainless	96476184		YES
203	Lock Ring for Flange		2/1-17	2	ø91.6x 5.0mm Stainless	96475396		YES

↑ Due to part changes over time, all position numbers (1-203) may not be used.

↑ This column indicates which pump model uses the spare part. If blank, the part is used in all models.

NOTES:

The first number is total number of stages.

The second number behind the slash (/) equals the number of impellers

Example: a CR120-2/1 has 2 chambers and 1 impeller (de-staged by 1).

- * 1 2 to 17 stage use position 3
 2 /1 stage use position 3a
 De-staging by two impellers use one 3a and one 3b
- ^^^ 2/1 and 2 stage = use 0
 3 to 6 stage = # of stages less 2
 7 to 10 stage = # of stages less 3
 12 to 17 stage = # of stages less 4
 De-staging by two impellers use 1 less than stated above.
- ^^^^ 2/1 to 6 stage = use 1
 7 to 10 stage = use 2
 12 to 17 stage = use 3
- ^^^^^ 2/1-2, 4, 6, 8, and 12 stage = use 1
 Exception to the above: low NPSH models
 2, 4, 6, 8 to 17 stage = use 1
 3, 5 and 7 stage = use 2
- ^^^^^^ 2/1 to 6 stage = use 1
 7 to 10 stage = use 2
 12 to 17 stage = use 3
 Exception to the above: low NPSH models
 2 to 6 stage = use 0
 7 to 10 stage = use 1
 12 to 17 stage = use 2
- ^+ **NPSH Models only**
 3, 6, 8 & 17 stage = use 1
 2, 4, 6, 10, 12 & 14 stage = use 2
- ^- **NPSH Models only**
 3, 6, 8 & 17 stage = use 1
- * Standard use 1. Back-to-Back or Tandem pump version use 2
- ** Standard use 1. Back-to-Back or Tandem pump version use 2
- *** Standard use 1. Back-to-Back or Tandem pump version use 2
- ⊖ Standard use 1. CR(I,N)20-2/1 replace with pos. 69a
- # stgs- Use the number of stages in standard models,
 less one in de-staged and Low NPSH models.
- # imp.- Use the number of stages in standard models,
 less one in de-staged and Low NPSH models.
- ◆◆ Standard use 2. Back-to-Back or Tandem pump version use 3,
 Cool Top use 1 EPDM or FKM and 2 FXM in lower hot section of pump.
- Standard use 2. Back-to-Back or Tandem pump version use 6
- L* Is a tip to tip length which includes the bends for slot engagement.
 Bottom tip to bend is 4.5mm shorter than the tip to tip value.

Key to Symbols

KITS	Recommended spare part
∅	Diameter
ANSI	American National Standards Institute
CPL	Complete Assembly – these parts consist of more than one component
EPDM	Ethylene Propylene (also known as EPR and EPT) – an elastic substance similar to rubber
FFKM	Kalrez Elastomer made by DuPont
FKM	Fluoro Elastomer (generic for Viton)
FXM	Fluoraz Elastomer made by Greene Tweed
IEC	International Electro-technical Commission (European standards)
M	International standard thread size designation (thread diameter in mm)
mm	Millimeter
MG	Identifies Grundfos motor type/size
N	Stamp code for 316 SS or similar
NBR	Buna - N (also known as Nitrile) – an elastic substance similar to rubber
NEMA	National Electrical Manufacturers Association
NPSH	Net Positive Suction Head
PTFE	Teflon
SiC	Silicon Carbide
SS	Stainless Steel
TC	Tungsten Carbide
UNC	Unified National Coarse – a standard for threads on bolts

Spare Part Kits **CR120**

SPARE PART KITS

Since certain pump parts can be expected to exhibit wear at the same time as related pump parts, they have been grouped into the following kits for your convenience. The numbers indicate the quantity of the part within each kit. Please order these kits using the kit material number at the top of the columns.

CR(I, N)20 SIC Bearing				Kit No. 96511824		
WEAR PARTS KIT 1-6				Kit No. 96511827		
WEAR PARTS KIT 7-10				Kit No. 96511830		
WEAR PARTS KIT 12-17				Kit No. 96511830		
Pos. No.	Description	Material No.	Qty. Included in each Kit			
4a	Chamber N Cpl. w/Pos.45 & 65 & SIC Bearing	96475768	1	2	3	
26b	Bolt for strap, M8 x 25mm, 316 SS w/Delta Seal	96416603	2	2	2	
26c	Washer for strap, A4, ø16.0/ø8.4x1.6mm	00ID3284	2	2	2	
45	Neck Ring, ø75.8 x ø59.95 x 1.5mm, PTFE-Acoflon 100	96487400	5	8	14	
47a	Bearing Ring/Spacer, SIC 150, ø23.4 x 14mm	96482117	1	2	3	
49c	Wear Ring, N, ø59.85 x 7.4mm	330054	6	10	17	
61	Stop Spacer, ø29.0 x ø18.4 x ø17.6 x ø15.0 x 9.5 x 2mm	330072	1	1	1	
62	Stop Ring, ø16.6 x ø15.0 x 1.6mm	330057	1	1	1	
64a	Spacing Pipe, ø21.5 x ø17.5 x 17.0mm	331416	1	2	3	
64b	Clamp, Splined, ø21.5 x ø17.6 x ø15.0 x 5.0mm	331401	1	1	1	
64c	Clamp, Splined, ø21.5 x ø17.6 x ø15.0 x 12.7mm	96496311	1	1	1	
64d	Spacing Pipe, ø21.5 x ø17.5 x 12.6mm	96491535	1	2	3	
65	Neck Ring Retainer, N, ø78.8 x ø61.5 x 6.7mm	330059	5	8	14	
66	Lock Washer Set of 2, ø13.5 x ø8.2 x 2.6mm	96417297	1	1	1	
67	Lock Nut, 13mm x M8	96496488	1	1	1	

STACK KITS (SIC) Pos.80	
Model	Material No.
CR120-2/1	96491772
CR120-2	96491773
CR120-3	96491774
CR120-4	96491775
CR120-5	96491776
CR120-6	96491777
CR120-7	96491778
CR120-8	96491779
CR120-10	96491780
CR120-12	96491781
CR120-14	96491782
CR120-17	96491783

***For 50 Hz operation only.

CR(I, N)20 Grafion Bearing				Kit No. 96511826		
WEAR PARTS KIT 1-6				Kit No. 96511829		
WEAR PARTS KIT 7-10				Kit No. 96511832		
WEAR PARTS KIT 12-17				Kit No. 96511832		
Pos. No.	Description	Material No.	Qty. Included in each Kit			
4a	Chamber N Cpl. w/Pos.45 & 65 & Grafion Bearing	96492510	1	2	3	
26b	Bolt for strap, M8 x 25mm, 316 SS w/Delta Seal	96416603	2	2	2	
26c	Washer for strap, A4, ø16.0/ø8.4x1.6mm	00ID3284	2	2	2	
45	Neck Ring, ø75.8 x ø59.95 x 1.5mm, PTFE-Acoflon 100	96487400	5	8	14	
47a	Bearing Ring/Spacer, TC, ø21.9 x ø17.6 x ø15.0 x 14mm	330085	1	2	3	
49c	Wear Ring, N, ø59.85 x 7.4mm	330054	6	10	17	
61	Stop Spacer, ø29.0 x ø18.4 x ø17.6 x ø15.0 x 9.5 x 2mm	330072	1	1	1	
62	Stop Ring, ø16.6 x ø15.0 x 1.6mm	330057	1	1	1	
64a	Spacing Pipe, ø21.5 x ø17.5 x 17.0mm	331416	1	2	3	
64b	Clamp, Splined, ø21.5 x ø17.6 x ø15.0 x 5.0mm	331401	1	1	1	
64c	Clamp, Splined, ø21.5 x ø17.6 x ø15.0 x 12.7mm	96496311	1	1	1	
64d	Spacing Pipe, ø21.5 x ø17.5 x 12.6mm	96491535	1	2	3	
65	Neck Ring Retainer, N, ø78.8 x ø61.5 x 6.7mm	330059	5	8	14	
66	Lock Washer Set of 2, ø13.5 x ø8.2 x 2.6mm	96417297	1	1	1	
67	Lock Nut, 13mm x M8	96496488	1	1	1	

CR(I, N)20 Bronze Bearing				Kit No. 96511825		
WEAR PARTS KIT 1-6				Kit No. 96511828		
WEAR PARTS KIT 7-10				Kit No. 96511831		
WEAR PARTS KIT 12-17				Kit No. 96511831		
Pos. No.	Description	Material No.	Qty. Included in each Kit			
4a	Chamber N Cpl. w/Pos.45 & 65 & Bronze Bearing	96492512	1	2	3	
26b	Bolt for strap, M8 x 25mm, 316 SS w/Delta Seal	96416603	2	2	2	
26c	Washer for strap, A4, ø16.0/ø8.4x1.6mm	00ID3284	2	2	2	
45	Neck Ring, ø75.8 x ø59.95 x 1.5mm, PTFE-Acoflon 100	96487400	5	8	14	
47a	Bearing Ring/Spacer, TC, ø21.9 x ø17.6 x ø15.0 x 14mm	330085	1	2	3	
49c	Wear Ring, N, ø59.85 x 7.4mm	330054	6	10	17	
61	Stop Spacer, ø29.0 x ø18.4 x ø17.6 x ø15.0 x 9.5 x 2mm	330072	1	1	1	
62	Stop Ring, ø16.6 x ø15.0 x 1.6mm	330057	1	1	1	
64a	Spacing Pipe, ø21.5 x ø17.5 x 17.0mm	331416	1	2	3	
64b	Clamp, Splined, ø21.5 x ø17.6 x ø15.0 x 5.0mm	331401	1	1	1	
64c	Clamp, Splined, ø21.5 x ø17.6 x ø15.0 x 12.7mm	96496311	1	1	1	
64d	Spacing Pipe, ø21.5 x ø17.5 x 12.6mm	96491535	1	2	3	
65	Neck Ring Retainer, N, ø78.8 x ø61.5 x 6.7mm	330059	5	8	14	
66	Lock Washer Set of 2, ø13.5 x ø8.2 x 2.6mm	96417297	1	1	1	
67	Lock Nut, 13mm x M8	96496488	1	1	1	

GASKET KIT (EPDM)				Kit No. 96509609																
GASKET KIT (FKM)				Kit No. 96509610																
GASKET KIT (FKM)				Kit No. 96534871																
GASKET KIT (FKM)				Kit No. 96533374																
GASKET KIT (EPDM)-Double Seal option.				Kit No. 96525433																
GASKET KIT (FKM)-Double Seal option.				Kit No. 96525434																
GASKET KIT (FKM/EPDM)-Double Seal option.				Kit No. 96525435																
GASKET KIT (FKM/EPDM)-Double Seal option.				Kit No. 96525436																
GASKET KIT (EPDM)-Cool Top option.				Kit No. 96525419																
GASKET KIT (FKM)-Cool Top option.				Kit No. 96525431																
GASKET KIT (FKM/EPDM)-Cool Top option.				Kit No. 96525432																
Pos. No.	Description	Material No.	Qty. Included in each Kit																	
37	Sleeve O-ring, EPDM (WRC NSF), ø170.7 x 3.3mm	96483101	2			3														
	Sleeve O-ring, FKM, ø170.7 x 3.3mm	96483102		2				3												
37b	Sleeve O-ring, FKM, ø171.25 x 3.3mm	96483109			2															2
	Sleeve O-ring, FFKM, ø170.7 x 3.3mm	96483140				2														
37c	Disc Plate O-ring, EPDM, ø155.0 x 3.0mm	96509703																		1
	Disc Plate O-ring, FKM, ø155.0 x 3.0mm	96480168																		1
38, 100(a,b)	Drain Plug O-ring, EPDM, ø16.3 x 2.4mm	00ID1288	3				7													4
	Drain Plug O-ring, FKM, ø16.3 x 2.4mm	00ID2231		3					7											4
	Drain Plug O-ring, FKM, ø16.3 x 2.4mm	96442869			3															3
	Drain Plug O-ring, FFKM, ø16.3 x 2.4mm	96428162				3														3
38a	Drain Plug O-ring, EPDM, ø5.3 x 2.4mm	00ID2142	1				1													1
	Drain Plug O-ring, FKM, ø5.3 x 2.4mm	00ID3945						1												1
	Drain Plug O-ring, FKM, ø5.3 x 2.4mm	96511292		1																1
	Drain Plug O-ring, FFKM, ø5.3 x 2.4mm	96511293				1														1
39	Flange O-ring, EPDM, ø90 x 3mm	96496200	2				2													1
	Flange O-ring, FKM, ø90 x 3mm	00ID2856		2					2											2
	Flange gasket, Fiber, 122mm x ø60 x ø44 x 2mm	420039	2	2	2	2	2	2	2	2	2	2	2	2	2	2	2	2	2	2
	Flange gasket, Fiber, ø102 x ø65 x 2mm	330035	2	2	2	2	2	2	2	2	2	2	2	2	2	2	2	2	2	2
	Flange gasket, Fiber, ø92 x ø49 x 2mm	00ID2582	2	2	2	2	2	2	2	2	2	2	2	2	2	2	2	2	2	2
60(a)	Stack Compression Spring, EPDM, ø11.0xø7.0x15.5mm	96503070	4				4													4
	Stack Compression Spring, FKM, ø11.0xø7.0x15.5mm	96503072		4					4											4
	Stack Compression Spring, PTFE, ø11.0xø7.0x15.5mm	96503071			4					4										4
109a	Disc Plate O-ring, EPDM, ø27.5 x 2.75mm	96483103																		1
	Disc Plate O-ring, FKM, ø27.5 x 2.75mm	96483104																		1
	Disc Plate O-ring, FKM, ø27.5 x 2.75mm	96483141																		1

SPARE PART KITS (Continued)

HQxx SHAFT SEAL KIT, BALANCED CARTRIDGE (Maximum allowed working PSI is 435) (Tandem Seal option Pumps require 2 of each Seal Kit)		Kit No. 96511848	Kit No. 96511849	Kit No. 96511844	Kit No. 96511847	Kit No. 96511846	Kit No. 96511845
Pos. No.	Description	Material No.	Qty. Included in each Kit				
105	HQBE	96484076*	1				
	HQBV	96484077*		1			
	HQQE	96484071*			1		
	HQQF	96484075*				1	
	HQQK	96484074*					1
	HQQV	96484072*					1
N/A	Grinding Device Tool for Emery Cloth	370711	1	1	1	1	1
N/A	Emery Cloth	370712	1	1	1	1	1

* Seal material number includes the Adjusting fork 96483950.

HUxx SHAFT SEAL KIT, BALANCED CARTRIDGE (Maximum allowed working PSI is 435) (Tandem Seal option Pumps require 2 of each Seal Kit)		Kit No. 96511836	Kit No. 96511839	Kit No. 96511838	Kit No. 96511837	Kit No. 96511840	Kit No. 96511843	Kit No. 96511842	Kit No. 96511841
Pos. No.	Description	Material No.	Qty. Included in each Kit						
105	HUBE	96483952*	1						
	HUBF	96483966*		1					
	HUBK	96483965*			1				
	HUBV	96483964*				1			
	HUUE	96483967*					1		
	HUUF	96484070*						1	
	HUUK	96483969*							1
	HUUV	96483968*							1
N/A	Grinding Device Tool for Emery Cloth	370711	1	1	1	1	1	1	1
N/A	Emery Cloth	370712	1	1	1	1	1	1	1

* Seal material number includes the Adjusting fork 96483950.

IEC COUPLING KIT		Kit No. 96511315	Kit No. 96511317	Kit No. 96511319	Kit No. 96511350	Kit No. 96511351	Kit No. 96511352	
Pos. No.	Description	Material No.	Qty. Included in each Kit					
9	Allen Screw, M6 x 20mm, Delta Seal	00ID7899	4	4				
	Allen Screw, M8 x 25mm, Delta Seal	00ID7900			4	4		
	Allen Screw, M10 x 25mm, Delta Seal	00ID7901					4 4	
10 10a	Shaft Pin, $\phi 5$ x 26mm, Stainless	310192		1	1	1	1	
	Coupling Half, F85, MG71, 37-55kW, $\phi 14/\phi 16$	480002	2					
	Coupling Half, F100, MG80, 75-1.1kW, $\phi 19/\phi 16$	480004		2				
	Coupling Half, F115, MG 90, 1.5-2.2kW, $\phi 24/\phi 16$	480006			2			
	Coupling Half, F130, MG100/112, 3.0-4.0 kW, $\phi 28/\phi 16$	480008				2		
	Coupling mach. set, F265, MG132, 5.5-7.5kW, $\phi 38/\phi 16$	96516772					1	
	Coupling mach. set, F300 MG160, 11.0-18.5kW, $\phi 42/\phi 16$	96516008						1
	N/A	Adjusting Fork	96483950	1	1	1	1	1

NEMA COUPLING KIT		Kit No. 96511353	Kit No. 96511354	Kit No. 96753660	Kit No. 96511355	Kit No. 96753661	Kit No. 96511356	
Pos. No.	Description	Material No.	Qty. Included in each Kit					
9	Allen Screw, M6 x 20mm, Delta Seal	00ID7899	4					
	Allen Screw, M10 x 25mm, Delta Seal	00ID7901		4	4	4	4	
10 10a	Shaft Pin, $\phi 5$ x 26mm, Stainless	310192	1	1	1	1	1	
	Coupling Half set, 56C, 1/3 - 2HP, $\phi 15.8 / \phi 16$	96516777	1					
	Cplg. Half set, 182/184TC, 3-5HP, std.-low, $\phi 28.5/\phi 16$	96516774		1				
	Cplg. Half set, 182/184TC, 3-5HP, opt.-high, $\phi 28.5/\phi 16$	96516009			1			
	Cplg. Half set, 213TC, 7.5-10HP, std.-low, $\phi 34.9/\phi 16$	96472175				1		
	Cplg. Half set, 213TC, 7.5-10HP, opt.-high, $\phi 34.9/\phi 16$	96516770					1	
	Cplg. Half set, 254TC-284/286TSC, 15-25HP, $\phi 41.2/\phi 16$	96516771						1
	N/A	Adjusting Fork	96483950	1	1	1	1	1

COUPLING GUARD KIT		Kit No. 96509611	Kit No. 96509612	Kit No. 96509613	Kit No. 96509614
Pos. No.	Description	Material No.	Qty. Included in each Kit		
7	Coupling Guard, W=127mm x H=70mm	96491001	2		
	Coupling Guard, W=127mm x H=90.5mm	96491002		2	
	Coupling Guard, W=157mm x H=125mm	96490657			2
	Coupling Guard, W=157mm x H=171mm	96490656			
7a	Screw comb.slot torx/straight slot 4 x 8mm	96488481	4	4	4

Spare Part Kits • Accessories **CR120**

SPARE PART KITS (Continued)

PLUG KIT		Kit No. 96511314	
Pos. No.	Description	Material No.	Qty. Included in each Kit
18	Priming/Vent Plug, G 1/2A, NV24 with NV9 x M8 stem	405150	1
23	G 1/2A, w/1/4" NPT threaded port, NV24	91120659	1
23c	1/4" NPT,SS SQHD	00ID7216	1
25	Drain Plug-solid stem, without O-rings, G 1/2A, NV24	96491043	1
38	O-ring, EPDM, Ø16.3 x 2.4mm	00ID1288	1
	O-ring, FKM, Ø16.3 x 2.4mm	00ID2231	1
38a	Drain Plug O-ring, EPDM, ø5.3 x 2.4mm	00ID2142	1
	Drain Plug O-ring, FKM, ø5.3 x 2.4mm	00ID3945	1
100	O-ring, EPDM, Ø16.3 x 2.4mm	00ID1288	2
	O-ring, FKM, Ø16.3 x 2.4mm	00ID2231	2

FLEXI FLANGE KIT FOR MEDIUM CR10, 15, & 20		Kit No. 96498841	
1-1/2" Threaded Cast Iron (232 PSI Max.)			
Pos. No.	Description	Material No.	Qty. Included in each Kit
12	Flange, Cast Iron, 1-1/2" - 11.5 NPT	96493637	2
35	Hex Head Bolt, M12 x 90mm, 8.8 DIN931, Delta Seal	96502505	4
36b	Nut, CS M12 x NV19mm, w/Delta Seal	00ID7917	4
39	Gasket, 122mm x ø60/ø44 x 2mm, KLINGERSIL C4430	420039	2

FLEXI FLANGE KIT FOR MEDIUM CRI (N)10, 15, & 20		Kit No. 96498837	
1-1/2" Stainless Steel (232 PSI Max.)			
Pos. No.	Description	Material No.	Qty. Included in each Kit
12	Flange, Stainless Steel 1-1/2" - 11.5 NPT	96490775	2
35	Hex Head Bolt, M12 x 80mm, ISO4014, DIN931	00ID9241	4
36b	Nut, M12 x NV19mm, 316SS	00ID0876	4
39	Gasket, 122mm x ø60/ø44 x 2mm, KLINGERSIL C4430	420039	2

FLEXI FLANGE KIT FOR MEDIUM CR10, 15, & 20		Kit No. 96498838	
2" Threaded Cast Iron (232 PSI Max.)			
Pos. No.	Description	Material No.	Qty. Included in each Kit
12	Flange, Cast Iron, 2" - 11.5 NPT	96493636	2
35	Hex Head Bolt, M12 x 90mm, 8.8 DIN931, Delta Seal	96502505	4
36b	Nut, CS M12 x NV19mm, w/Delta Seal	00ID7917	4
39	Gasket, 124mm x ø80/ø59 x 2mm, KLINGERSIL C4430	320120	2

FLEXI FLANGE KIT FOR MEDIUM CRI (N)10, 15, & 20		Kit No. 96498839	
2" Stainless Steel (232 PSI Max.)			
Pos. No.	Description	Material No.	Qty. Included in each Kit
12	Flange, Stainless Steel 2" - 11.5 NPT	96490782	2
35	Hex Head Bolt, M12 x 80mm, ISO4014, DIN931	00ID9241	4
36b	Nut, M12 x NV19mm, 316SS	00ID0876	4
39	Gasket, 124mm x ø80/ø59 x 2mm, KLINGERSIL C4430	320120	2

FLEXI CLAMP FLANGE KIT FOR MEDIUM CRI(N)10, 15 & 20		Kit No. 96511400	
2" Cast Iron Flange		EPDM	
(Conversion max. allowable operating pressure 232)		FKM	
Pos. No.	Description	Material No.	Qty. Included in each Kit
12a	Adapter Flange DN50 for ANSI pos.201/Flexi Base (232 PSI)	96491152	2
35	Hex Head Bolt, M12 x 90mm, 8.8 DIN931, Delta Seal	96502505	4
36b	Nut, CS M12 x NV19mm, w/Delta Seal	00ID7917	4
39b	O-ring, EPDM, ø64.5 x 3mm	00ID2143	2
	O-ring, FKM, ø64.5 x 3mm	00ID4038	2
201	Flange, ANSI, DIN, JIS, Cast Iron	96476189	2
203	Lock Ring, Stainless	96475396	2

FLEXI CLAMP FLANGE KIT FOR MEDIUM CRI(N)10, 15 & 20		Kit No. 96511402	
2" Stainless Steel Flange		EPDM	
(Conversion max. allowable operating pressure 232)		FKM	
Pos. No.	Description	Material No.	Qty. Included in each Kit
12a	Adapter Flange DN50 for ANSI pos.201/Flexi Base (232 PSI)	96491152	2
35	Hex Head Bolt, M12 x 80mm, ISO4014, DIN931	00ID9241	4
36b	Nut, M12 x NV19mm, 316SS	00ID0876	4
39b	O-ring, EPDM, ø64.5 x 3mm	00ID2143	2
	O-ring, FKM, ø64.5 x 3mm	00ID4038	2
201	Flange, ANSI, DIN, JIS, Stainless Steel	96476184	2
203	Lock Ring, Stainless	96475396	2

FLEXI CLAMP KIT FOR MEDIUM CRI(N)10, 15 & 20		Kit No. 96500271	
1-1/2" Internal Threaded SS Pipe Stub (232 PSI Max.)		EPDM	
		FKM	
Pos. No.	Description	Material No.	Qty. Included in each Kit
12b	Stainless, Internal 1-1/2" - 11.5 NPT	96498795	2
12c	Clamp for Flexi Base & pos.12b	00ID7195	4
35b	Screw for Pos. 12c, M10 x 45mm - A2, RR DIN933	00ID7189	4
35c	Nut for Pos. 35b, M10, 304SS, A2, RR DIN934	00ID3570	4
39b	O-ring, EPDM, ø71.0 x 4.0mm	00ID7192	2
	O-ring, FKM, ø71.0 x 4.0mm	00ID7193	2

SPARE PART KITS *(Continued)*

FLEXI CLAMP KIT FOR MEDIUM CRI(N)10, 15 & 20		EPDM	Kit No.	96500273	
2" Internal Threaded SS Pipe Stub (232 PSI Max.)		FKM	Kit No.	96500274	
Pos. No.	Description	Material No.	Qty. Included in each Kit		
12b	Stainless, Internal 2" -11.5 NPT	96498796	2	2	
12c	Clamp for Flexi Base & pos.12b	00ID7195	4	4	
35b	Screw for Pos. 12c, M10 x 45mm - A2, RR DIN933	00ID7189	4	4	
35c	Nut for Pos. 35b, M10, 304SS, A2, RR DIN934	00ID3570	4	4	
39b	O-ring, EPDM, ø71.0 x 4.0mm	00ID7192	2		
	O-ring, FKM, ø71.0 x 4.0mm	00ID7193		2	

FLEXI CLAMP KIT FOR MEDIUM CRI(N)10, 15 & 20		EPDM	Kit No.	96508602	
2-1/2" Internal Threaded SS Pipe Stub (232 PSI Max.)		FKM	Kit No.	96508603	
Pos. No.	Description	Material No.	Qty. Included in each Kit		
12b	Stainless, Internal 2" -11.5 NPT	96498797	2	2	
12c	Clamp for Flexi Base & pos.12b	00ID7195	4	4	
35b	Screw for Pos. 12c, M10 x 45mm - A2, RR DIN933	00ID7189	4	4	
35c	Nut for Pos. 35b, M10, 304SS, A2, RR DIN934	00ID3570	4	4	
39b	O-ring, EPDM, ø71.0 x 4.0mm	00ID7192	2		
	O-ring, FKM, ø71.0 x 4.0mm	00ID7193		2	

Air Vent Kit			Kit No.	91136564	
56C to 213TC .33-10HP; .37 to 7.5 kW			Kit No.	91136565	
Pos. No.	Description	Material No.	Qty. Included in each Kit		
116	Counter Nut for Pipe 117, G1/2	96506709	2	2	
117	Air Vent Pipe for 118, G1/2 , 150x90	330272	1		
	Air Vent Pipe for 118, G1/2 , 185x90	96521537		1	
118	Air vent type 1511-AV - 5/6430	96427483	1	1	





ACCESSORIES

ANSI COMPANION FLANGES FOR MEDIUM CR			Kit No.	339919	
2" Threaded Stainless Steel, 300 Lb. Class					
Pos. No.	Description	Material No.	Qty. Included in each Kit		
N/A	Nut, HEX 5/8"-11 UNC, 18-8SS	0ID00164		16	
N/A	Plain Bolt, 5/8" -11 x 3", 18-8SS	0ID00174		16	
N/A	Flange, Stainless Steel, 2"	00ID7240		2	
N/A	Gasket - Flange, 2", 250#, Cut Ring	00ID2747		2	

VICTAULIC, 2" COUPLING KIT FOR MEDIUM CRI(N)10, 15 & 20		EPDM	Kit No.	331301	
(1,000 PSI Max.)		FKM	Kit No.	0ID00128	
Pos. No.	Description	Material No.	Qty. Included in each Kit		
N/A	Stainless 316, Nipple - 2" NPT External Thread	330130	2	2	
N/A	Coupling Set 2", EPDM	00ID2643	2		
N/A	Coupling Set 2", FKM	0ID00122		2	

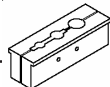
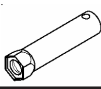

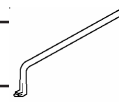
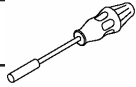
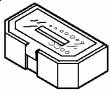

SPECIAL TOOLS

Tools not generally available from normal sources.

Mat. No.	Description and Use	
00SV0040	Shaft Holder for Dismantling/Assembly Used to hold and protect the shaft during dismantling and assembly.	
00SV2107	Tubular Box Spanner for Shaft Seal 41.0 mm Used to install and remove the shaft seal. Fits a 1/2" drive ratchet.	
00SV2101	Ring Insert Tool for Shaft Seal + Square 41 mm x 1/2" drive	
00SV0239	Puller for Neck Ring Used to remove the Neck Ring from Chamber.	
00SV2011	Bit Holder Used with Bits Kit, 1/4"	
00SV2010	Bits Kit NV 5 mm for M6, 1/4" NV 6 mm for M8, 1/4" NV 8 mm for M10, 1/4"	
00SV2012	Hexagon Socket Bit Used for Shaft Seal NV 2.5 mm for M5, 1/4"	
00SV2127	Bearing Removal Punch	

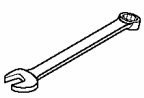
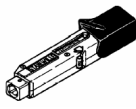
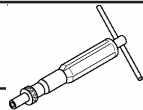
STANDARD TOOLS

In addition to being available from Grundfos, comparable tools can be purchased through normal sources.

Mat. No.	Description and Use	
00SV0083 00SV0055 00SV0054 00SV0122	Wrenches Used to tighten various nuts. NV 10 mm for M6 NV 13 mm for M8 NV 19 mm for M12 NV 24 mm for M16	
00SV0292 00SV0269 00SV0400	Torque Wrench Used to torque various screws. 4-20 Nm, 9 x 12 20-100 Nm, 9 x 12 40-200 Nm, 14x18	
00SV0438	Torque Screwdriver Used to tighten various nuts. 1-6 Nm, 1/4"	
00SV0295 00SV0401	Ratchet Spanner for all Adapters 9 mm x 12 mm, 1/2" 14 mm x 18 mm, 1/2"	
00SV0296 00SV0297 00SV0298	Socket Spanner with Inside Hex NV 5 mm for M6, 1/2" x 1/2" NV 6 mm for M8, 1/2" x 1/2" NV 8 mm for M10, 1/2" x 1/2"	
00SV0310 00SV0294 00SV0271 00SV0524	Ring Spanner NV 10 mm, 9 x 12, for M6 NV 13 mm, 9 x 12, for M8 NV 19 mm, 9 x 12, for M12 NV 24 mm, 14 x 18, for M16	
00SV2013 00SV0267	Socket Spanner NV 13 mm for M8, 1/2" drv. NV 19 mm for M12, 1/2" drv.	

L-CR-SM-046 | 8/07
PRINTED IN USA