

# CR, CRI, CRX, CRN, CRT

## Vertical Multistage Centrifugal Pumps

Please leave these instructions with  
the pump for future reference



# SAFETY WARNING

## Electrical Work

All electrical work should be performed by a qualified electrician in accordance with the latest edition of the National Electrical Code, local codes and regulations.

## Shock Hazard

A faulty motor or wiring can cause electrical shock that could be fatal, whether touched directly or conducted through standing water. For this reason, proper grounding of the pump to the power supply's grounding terminal is required for safe installation and operation.

In all installations, the above-ground metal plumbing should be connected to the power supply ground as described in Article 250-80 of the National Electrical Code.

# Nameplate Data

### Type key

#### CR, CRI, CRN 1s, 1, 3, 5, 10, 15, and 20

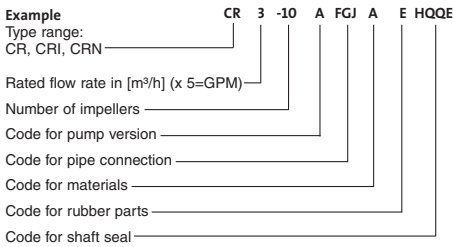

#### CR, CRX, CRN 8 and 16

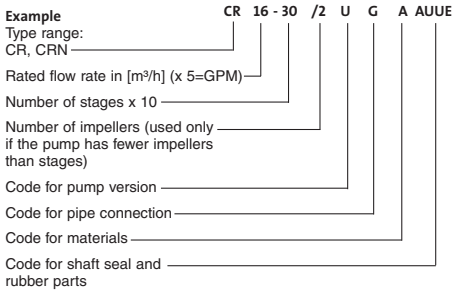

#### CR, CRN 32, 45, 64, AND 90

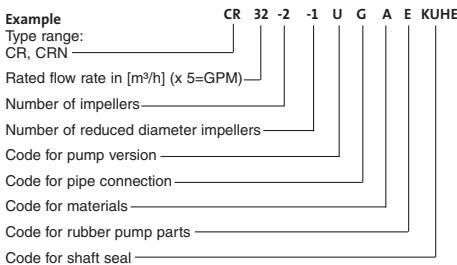

### Codes

#### Example Pump version

A	*Basic version pump	U	FGJ	A	E	HQQE
U	*NEMA version pump					
B	Oversize motor, one flange size bigger					
F	CR pump for high temperatures (Cool-Top™)					
H	Horizontal version					
HS	High pressure pump with over-synchronous speed and reversed direction of rotation					
I	Different pressure rating					
K	Low NPSH					
M	Magnetic drive					
P	Undersize motor					
R	Horizontal version with bearing bracket					
SF	High pressure pump with reversed chamber stack and direction of rotation					
T	Oversize motor, two flange sizes bigger					
X	**Special version					

#### Pipe connection

A	Oval flange
B	NPT thread
C	Clamp coupling
CA	FlexiClamp
CX	TriClamp
F	DIN flange
G	ANSI flange
J	JIS flange
N	Changed diameter of ports
O	Externally threaded, union
P	PJF coupling
X	Special version

#### Materials

A	Basic version
D	Carbon-graphite filled PTFE (bearings)
G	Stainless steel parts of 316 SS
GI	Base plate and flanges of 316 SS
I	Stainless steel parts of 304 SS
II	Base plate and flange of 304 SS
K	Bronze (bearings)
S	SIC bearing ring + PTFE neck ring (only CR, CRN 32 to 90)
T	Titanium
X	Special version

#### Code for rubber parts

E	EPDM
F	FXM (Flouraz®)
K	FFKM (Kalrez®)
V	FKM (Viton®)

#### Shaft seal

A	O-ring seal with fixed driver
B	Rubber bellows seal
D	O-ring seal, balanced
E	Cartridge seal with O-ring
H	Balanced cartridge seal with O-ring
K	Cartridge shaft seal with metal bellows
O	Double seal, back to back
P	Double seal, tandem
R	O-ring seal with reduced face
X	Special version

B	Carbon, synthetic resin-impregnated
H	Cemented tungsten carbide, embedded hybrid
Q	Silicon carbide
U	Cemented tungsten carbide

E	EPDM
F	FXM (Flouraz®)
K	FFKM (Kalrez®)
V	FKM (Viton®)

\* In August 2003 the NEMA pump code was discontinued for all material numbers created by GRUNDFOS manufacturing companies in North America. The NEMA version pump code will still remain in effect for existing material numbers. NEMA version pumps built in North America after this change will have either an A or U as the pump version code depending on the date the material number was created.

\*\* If a pump incorporates more than two pump versions, the code for the pump version is X. X also indicates special pump versions not listed above.

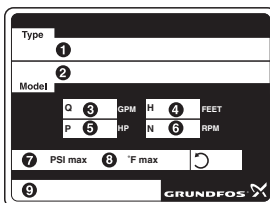

- Type designation
- Model, material number, production code
- Gallons per minute at rated RPM
- Head in feet at nameplate flow
- Pump horsepower
- Rated RPM
- Maximum PSI
- Maximum fluid temperature
- Production country

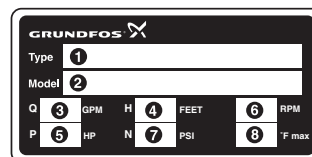

### Model Key

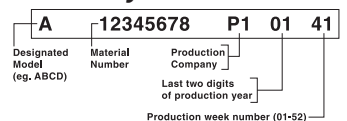

# Pre-installation Checklist

## 1. Confirm you have the right pump

Read the pump nameplate to make sure it is the one you ordered.

CR	— Centrifugal pump with standard cast iron and 304 stainless steel construction
CRI or CRX	— Centrifugal pump; all parts in contact with water are 304 stainless steel construction
CRN	— Centrifugal pump; all parts in contact with water are 316 stainless steel construction
CRT	— Centrifugal pump; all parts in contact with water are titanium construction
CRE	— Centrifugal pump with a Grundfos MLE VFD motor attached

## 2. Check the condition of the pump

The shipping carton your pump came in is specially designed around your pump during production to prevent damage. As a precaution, the pump should remain in the carton until you are ready to install it. Examine the pump for any damage that may have occurred during shipping. Examine any other parts of the shipment as well for any visible damage.

**If the pump is shipped as a complete unit (motor attached to pump end), the position of the coupling (that connects the pump shaft to the motor shaft) is set at factory specifications. No adjustment is required. If the unit is delivered as a pump end only, follow the adjustment procedures on pages 10-11.**

**Pump without Motor (CR(I)(N) 1s, 1, 3, 5, 10, 15, and 20 Only):** If you purchased a pump without a motor, the shaft seal has been set by the factory. Do not loosen the three set screws on the shaft seal when attaching the motor.

**Pump without Motor (CR(N) 32, 45, 64 & 90 Only):** If you purchased a pump without a motor, you must install the seal. The seal is protected in its own sub boxing within the pump packaging crate. To protect the shaft and bearings during shipment, a shaft holder protective device is used. This device must be removed prior to installation of the seal. Read the seal installation instructions which are included in the pump package.

## 3. Verify electrical requirements

Verification of the electrical supply should be made to be certain the voltage, phase and frequency match that of the pump motor. The proper operating voltage and other electrical information can be found on the motor nameplate. These motors are designed to run on  $\pm 10\%$  of the nameplate-rated voltage. For dual-voltage motors, the motor should be internally connected to operate on the voltage closest to the 10% rating, i.e., a 208 voltage motor wired per the 208 volt connection diagram. The wiring connection diagram can be found on either a plate attached to the motor or on a diagram inside the terminal box cover. If voltage variations are larger than  $\pm 10\%$ , do not operate the pump.

## 4. Is the application correct for this pump?

Compare the pump's nameplate data or its performance curve with the application in which you plan to install it. Will it perform the way you want it to perform? Also, make sure the application falls within the following limits:

Type	Designed to pump...
CR	Hot and chilled water, boiler feed, condensate return, glycols and solar thermal fluids.
CRI/CRN/CRX	Deionized, demineralized and distilled water. Brackish water and other liquids unsuitable for contact with iron or copper alloys. (Consult manufacturer for specific liquid compatibilities.)
CRN-SF	High pressure washdown, reverse osmosis, or other high pressure applications.
CRT	Salt water, chloride based fluids and fluids approved for titanium.

## Operating Conditions

Pump	Fluid Temperatures
CR(I)(N) 1s, 3, 5, 10, 15, and 20	-4 to +248°F (-20 to +120°C)
*CR(N) 32, 45, 64, and 90	-22 TO +248°F (-30 TO +120°C)
CR(N)(X)(T) 2, 4, 8, 16	-4 to +248°F (-20 to +120°C)
CRN-SF	-4 to +221°F (-15 to +105°C)
with Cool-Top™	up to +356°F (+180°C)

All motors are designed for continuous duty in +104°F (+40°C) ambient air conditions. For higher ambient temperature conditions consult Grundfos.

\* xUBE Shaft Seals are recommended for temperatures above +200°F. Pumps with hybrid shaft seals can only operate up to +200°F (+90°C). Pumps with xUUE shaft seals can be operated down to -40°F (-40°C) (where "x" is the seal type).

# Pre-installation Checklist (continued)

## Minimum Inlet Pressures

All CR, CRI, CRX, CRN  
CRN-SF

NPSHR + 2 feet  
29 psi (2 bar)

## Maximum Inlet Pressures

Pump Type	50 Hz Stages	60 Hz Stages	Max psi/bar
CR, CRI, CRN 1s	2 to 36	2 to 25 27	145 / 10 217 / 15
CR, CRI, CRN 1	2 to 36	2 to 25 27	145 / 10 217 / 15
CR, CRI, CRN 3	2 to 29 31 to 36	2 to 15 17 to 25	145 / 10 217 / 15
CR, CRI, CRN 5	3 to 16 18 to 36	2 to 9 10 to 24	145 / 10 217 / 15
CR, CRI, CRN 10	1 to 6 7 to 22	1 to 5 6 to 18	116 / 8 145 / 10
CR, CRI, CRN 15	1 to 3 4 to 17	1 to 2 3 to 12	116 / 8 145 / 10
CR, CRI, CRN 20	1 to 3 4 to 17	1 2 to 10	116 / 8 145 / 10
CR, CRN 32	1-1 to 4 5-2 to 10 11 to 14	1-1 to 2 3-2 to 6 7-2 to 11-2	58 / 4 145 / 10 217 / 15
CR, CRN 45	1-1 to 2 3-2 to 5 6-2 to 13-2	1-1 to 1 2-2 to 3 4-2 to 8-1	58 / 4 145 / 10 217 / 15
CR, CRN 64	1-1 to 2-2 2-1 to 4-2 4-1 to 8-1	1-1 1 to 2-1 2 to 5-2	58 / 4 145 / 10 217 / 15
CR, CRN 90	1-1 to 1 2-2 to 3-2 3 to 6	1-1 to 1 2-2 to 4-1	58 / 4 145 / 10 217 / 15
CRT 2	2 to 11 13 to 26	2 to 6 7 to 18	145 / 10 217 / 15
CRT 4	1 to 12 14 to 22	1 to 7 8 to 16	145 / 10 217 / 15
CRT 8	1 to 20	1 to 16	145 / 10
CRT 16	2 to 16	2 to 10	145 / 10
CR, CRX, CRN 8	1 to 6 7 to 20	1 to 4 5 to 16	87 / 6 145 / 10
CR, CRX, CRN 16	2 to 3 4 to 16	2 to 3 4 to 10	87 / 6 145 / 10
CRN-SF	all	all	72 / 5* 362 / 25**

\* while pump is off or during start-up

\*\* during operation

## Maximum Operating Pressures

at 250° F (194° F for CRN-SF)

Pump type/ connection	50 Hz Stages	60 Hz Stages	Max psi/bar
CR, CRI, CRN 1s			
Oval flange	1 to 23	1 to 17	232 / 16
FGJ, PJE	1 to 36	1 to 27	362 / 25
CR, CRI, CRN 1			
Oval flange	1 to 23	1 to 17	232 / 16
FGJ, PJE	1 to 36	1 to 27	362 / 25
CR, CRI, CRN 3			
Oval flange	1 to 23	1 to 17	232 / 16
FGJ, PJE	1 to 36	1 to 27	362 / 25
CR, CRI, CRN 5			
Oval flange	1 to 22	1 to 16	232 / 16
FGJ, PJE	1 to 36	1 to 24	362 / 25
CR, CRI, CRN 10			
Oval flange		1 to 10	145 / 10
Oval flange	1 to 16		232 / 16
FGJ, GJ, PJE	1 to 16	1 to 10	232 / 16
FGJ, GJ, PJE	17 to 22	12 to 17	362 / 25
CR, CRI, CRN 15			
Oval flange	1 to 7	1 to 5	145 / 10
FGJ, GJ, PJE	1 to 10	1 to 8	232 / 16
FGJ, GJ, PJE	12 to 17	9 to 12	362 / 25
CR, CRI, CRN 20			
Oval flange	1 to 7	1 to 5	145 / 10
FGJ, GJ, PJE	1 to 10	1 to 7	232 / 16
FGJ, GJ, PJE	12 to 17	8 to 10	362 / 25
CR, CRN 32			
	1-1 to 7 8-2 to 12 13-2 to 14	1-1 to 5 6-2 to 8 9-2 to 11-2	232 / 16 362 / 25 580 / 40
CR, CRN 45			
	1-1 to 5 6-2 to 9 10-2 to 13-2	1-1 to 4-2 4-1 to 6 7-2 to 8-1	232 / 16 362 / 25 580 / 40
CR, CRN 64			
	1-1 to 5 6-2 to 8-1	1-1 to 3 4-2 to 5-2	232 / 16 362 / 25
CR, CRN 90			
	1-1 to 4 5-2 to 6	1-1 to 3 4-2 to 4-1	232 / 16 362 / 25
CRT 2	2 to 26	2 to 18	305 / 21
CRT 4	1 to 22	1 to 16	305 / 21
CR, CRX, CRN, CRT 8	1 to 12 14 to 20	1 to 8 10 to 16	232 / 16 362 / 25
CR, CRX, CRN, CRT 16	1 to 8 10 to 16	1 to 8 10 to 12	232 / 16 362 / 25

Consult Grundfos for other working conditions.

## Select pump location

The pump should be located in a dry, well-ventilated area which is not subject to freezing or extreme variation in temperature. Care must be taken to ensure the pump is mounted at least 6 inches (150 mm) clear of any obstruction or hot surfaces. The motor requires an adequate air supply to prevent overheating and adequate vertical space to remove the motor for repair. For open systems requiring suction lift the pump should be located as close to the water source as possible to reduce piping losses.

## Foundation

Concrete or similar foundation material should be used to provide a secure, stable mounting base for the pump. Bolt hole center line dimensions for the various pump types are given in Figure 1. Secure the pump to the foundation using all four bolts and shim pump base to assure the pump is vertical and all four pads on the base are properly supported. Uneven surfaces can result in pump base breakage when mounting bolts are tightened.

The pump can be installed vertically or horizontally (see drawing at right). Ensure that an adequate supply of cool air reaches the motor cooling fan. The motor must never fall below the horizontal plane.

Arrows on the pump base show the direction of flow of liquid through the pump.

To minimize possible noise from the pump, it is advisable to fit expansion joints on either side of the pump and anti-vibration mountings between the foundation and the pump.

Isolating valves should be fitted either side of the pump to avoid draining the system if the pump needs to be cleaned, repaired or replaced.

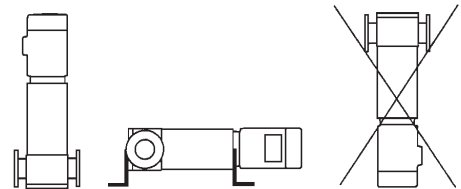

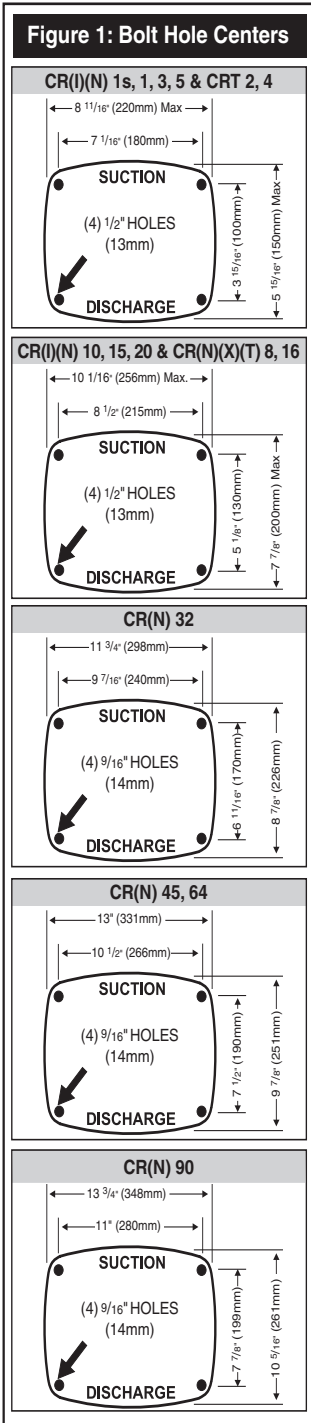

## Pipework



**NOTE:** The CR(N) pumps are shipped with covered suction and discharge. The covers must be removed before the final pipe flange to pump connections are made.

## Suction pipe

The suction pipe should be adequately sized and run as straight and short as possible to keep friction losses to a minimum (minimum of four pipe diameters straight run prior to the suction flange). Avoid using unnecessary fittings, valves or accessory items. Butterfly or gate valves should only be used in the suction line when it is necessary to isolate a pump because of a flooded suction condition. This would occur if the water source is above the pump. See Figures 2 and 3. Flush piping prior to pump installation to remove loose debris.

### Flooded Suction

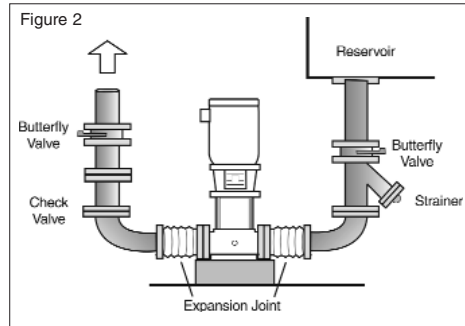

### Suction Lift\*

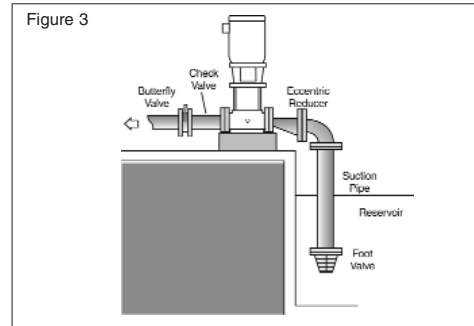

\* CRN-SF pumps cannot be used for suction lift. The suction pipe should have a fitting on it for priming.

## Minimum suction pipe sizes

The following recommended suction pipe sizes are the smallest sizes which should be used with any specific CR pump type. The suction pipe size should be verified with each installation to ensure good pipe practices are being observed and excess friction losses are not encountered. High temperatures may require larger diameter pipes to reduce friction and improve NPHSA.

CR(I)(N) 1s, 1, 3, CRT 2	1"	Nominal diameter sch 40 pipe
CR(I)(N) 5, CRT 4	1 1/4"	Nominal diameter sch 40 pipe
CR(I)(N)(X) 10, 15, 20, 8, 16	2"	Nominal diameter sch 40 pipe
CR(N) 32	2 1/2"	Nominal diameter sch 40 pipe
CR(N) 45	3"	Nominal diameter sch 40 pipe
CR(N) 64	4"	Nominal diameter sch 40 pipe
CR(N) 90	4"	Nominal diameter sch 40 pipe

## Discharge piping

It is suggested that a check valve and isolation valve be installed in the discharge pipe. Pipe, valves and fittings should be at least the same diameter as the discharge pipe or sized in accordance with good piping practices to reduce excessive fluid velocities and pipe friction losses. **Pipe, valves and fittings must have a pressure rating equal to or greater than the maximum system pressure.** Before the pump is installed it is recommended that the discharge piping be pressure checked to at least the maximum pressure the pump is capable of generating or as required by codes or local regulations.

Whenever possible, avoid high pressure loss fittings, such as elbows or branch tees directly on either side of the pump. The piping should be adequately supported to reduce thermal and mechanical stresses on the pump. Good installation practice recommends the system be thoroughly cleaned and flushed of all foreign materials and sediment prior to pump installation. Furthermore, the pump should never be installed at the lowest point of the system due to the natural accumulation of dirt and sediment. If there is excessive sediment or suspended particles present, it is advised a strainer or filter be used. Grundfos recommends that pressure gauges be installed on inlet and discharge flanges or in pipes to check pump and system performance.



**NOTE:** To avoid problems with waterhammer, fast closing valves must not be used in CRN-SF applications.

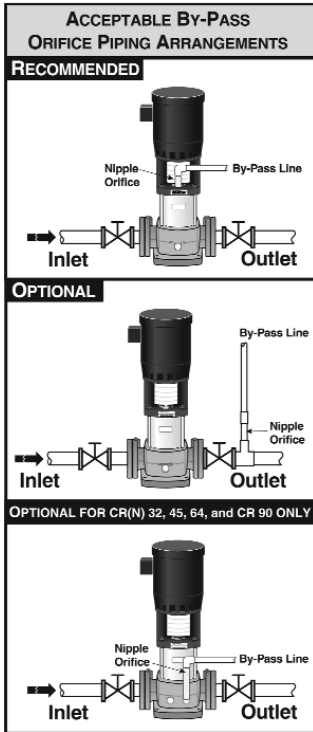

Table A  
Minimum Continuous Duty Flow Rates for CR(I)(X)(N)(T)

Pump Type	Min. Flow in GPM at Liquid Temperature			Cool-Top™
	min°F to 176°F min°C to 80°C	at 210°F at 99°C	at 248°F at 120°C	at 356°F at 180°C
CR, CRI, CRN 1s	0.5	0.7	1.2	1.2*
CR, CRI, CRN 1	0.9	1.3	2.3	2.3*
CR, CRI, CRN 3	1.6	2.4	4.0	4.0*
CR, CRI, CRN 5	3.0	4.5	7.5	7.5*
CR, CRI, CRN 10	5.5	8.3	14	14*
CR, CRI, CRN 15	9.5	14	24	24*
CR, CRI, CRN 20	11	17	28	28*
CR, CRN 32	14	21	35	35*
CR, CRN 45	22	33	55	55*
CR, CRN 64	34	51	85	85*
CR, CRN 90	44	66	110	110*
CRT 2	1.3	2.0	3.3	N/A
CRT 4	3.0	4.5	7.5	N/A
CR, CRX, CRN, CRT 8	4.0	6.0	10	10*
CR, CRX, CRN, CRT 16	8.0	12	20	20*

\*Grundfos Cool-Top is only available in the following pump types.

Pump Type	CR 1s	CR 1	CR 3	CR 5	CR 10	CR 15	CR 20	CR 32	CR 45	CR 64	CR 90	CR 8	CR 16
Standard (CR)								•	•	•	•		
I Version (CRI)	•	•	•	•	•	•	•						
N Version (CRN)	•	•	•	•	•	•	•	•	•	•	•	•*	•*

\* CRN 8 and 16 are only available in CRN-S. A CRN-S is a CRN pump without staybolts. All rubber parts are FXM.

## Check valves

A check valve may be required on the discharge side of the pump to prevent the pump's inlet pressure from being exceeded. For example, if a pump with no check valve is stopped because there is no demand on the system (all valves are closed), the high system pressure on the discharge side of the pump will "find" its way back to the inlet of the pump. If the system pressure is greater than the pump's maximum inlet pressure rating, the limits of the pump will be exceeded and a check valve needs to be fitted on the discharge side of the pump to prevent this condition. **This is especially critical for CRN-SF applications because of the very high discharge pressures involved. As a result, most CRN-SF installations require a check valve on the discharge piping.**

## Bypass

A bypass should be installed in the discharge pipe if there is any possibility the pump may operate against a closed valve in the discharge line. Flow through the pump is required to ensure adequate cooling and lubrication of the pump is maintained. See Table A for minimum flow rates. Elbows should be a minimum of 12" from the orifice discharge to prevent erosion.

## Temperature rise

It may sometimes be necessary to stop the flow through a pump during operation. At shut-off, the power to the pump is transferred to the pumped liquid as head, causing a temperature rise in the liquid. The result is risk of excess heating of and consequent damage to the pump. The risk depends on the temperature of the pumped liquid and for how long the pump is operating without flow. (See temperature rise chart.)

## Conditions/Reservations

The listed times are subject to the following conditions/reservations:

- No exchange of heat with the surroundings.
- The pumped liquid is water with a specific heat of  $1.0 \frac{\text{Btu}}{\text{lb} \cdot \text{F}}$  ( $4.18 \frac{\text{kJ}}{\text{kg} \cdot \text{C}}$ ).
- Pump parts (chambers, impellers and shaft) have the same thermal capacity as water.
- The water in the base and the pump head is not included.

These reservations should give sufficient safety margin against excessive temperature rise. The maximum temperature must not exceed the pump maximum rating.

## For Pump Ends With Bellows Seals Only (CR 2, 4, 8, 16)

Remove shaft seal protectors before installing motor (see diagram at below).

1. Remove coupling guards.
2. Remove coupling halves.
3. Remove shaft seal protectors.
4. Follow motor replacement instructions on page 10.

Pump Type	Time for Temperature Rise of 18° F (10°C)	
	Seconds	Minutes
CR 1s, 1, 3	210	3.5
CR 5	240	4.0
CR 10	210	3.5
CR 15	150	2.5
CR 20	120	2.0
CR 32, 45, 64, 90	60	1.0

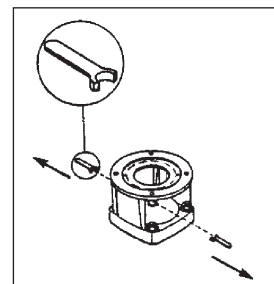

# Electrical

## WARNING



THE SAFE OPERATION OF THIS PUMP REQUIRES THAT IT BE GROUNDED IN ACCORDANCE WITH THE NATIONAL ELECTRICAL CODE AND LOCAL GOVERNING CODES OR REGULATIONS. CONNECT THE GROUND WIRE TO THE GROUNDING SCREW IN THE TERMINAL BOX AND THEN TO THE **ACCEPTABLE** GROUNDING POINT.

All electrical work should be performed by a qualified electrician in accordance with the latest edition of the National Electrical Code, local codes and regulations.

## Motor

Grundfos CR pumps are supplied with heavy-duty 2-pole (3600 RPM nominal), ODP or TEFC, NEMA C frame motors selected to our rigid specifications. Motors with other enclosure types and for other voltages and frequencies are available on a special-order basis. CRN-SF pumps are supplied with an IEC (metric) type motor with a reverse thrust bearing. If you are replacing the pumping unit, but are using a motor previously used on another CR pump, be sure to read the "Motor Replacement" section on page 10 for proper adjustment of the coupling height.

## Position of Terminal Box

The motor terminal box can be turned to any of four positions in 90° steps. To rotate the terminal box, remove the four bolts securing the motor to the pump but do not remove the shaft coupling; turn the motor to the desired location; replace and securely tighten the four bolts. See Figure 4.

## Field Wiring

Wire sizes should be based on the current carrying properties of a conductor as required by the latest edition of the National Electrical Code or local regulations. Direct on line (D.O.L.) starting is approved due to the extremely fast run-up time of the motor and the low moment of inertia of pump and motor. If D.O.L. starting is not acceptable and reduced starting current is required, an auto transformer, resistant starter or soft start should be used. It is suggested that a fused disconnect be used for each pump where service and standby pumps are installed.

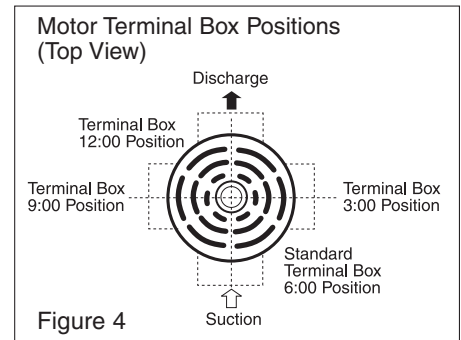

## Motor Protection

### 1. Single-Phase Motors:

With the exception of 7 1/2 and 10 HP motors which require external protection, single-phase CR pumps are equipped with multi-voltage, squirrel-cage induction motors with built-in thermal protection.

### 2. Three-Phase Motors

CR pumps with three-phase motors must be used with the proper size and type of motor-starter to ensure the motor is protected against damage from low voltage, phase failure, current imbalance and overloads. A properly sized starter with manual reset and ambient-compensated extra quick trip in all three legs should be used. The overload should be sized and adjusted to the full-load current rating of the motor. Under no circumstances should the overloads be set to a higher value than the full load current shown on the motor nameplate. This will void the warranty. Overloads for auto transformers and resistant starters should be sized in accordance with the recommendations of the manufacturer. Three phase MLE motors (CRE-Pumps) require only fuses as a circuit breaker. They do not require a motor starter. Check for phase imbalance (worksheet is provided on page 15).

**NOTE: Standard allowable phase imbalance difference is 5%.**

### 3. CRN-SF

The CRN-SF is typically operated in series with a feed pump. Because the maximum allowable inlet pressure of the CRN-SF increases from 73 psi (when pump is off and during start-up) to 365 psi (during operation), a control device must be used to start the CRN-SF pump one second before the feed pump starts. Similarly, the CRN-SF must stop one second after the feed pump stops.

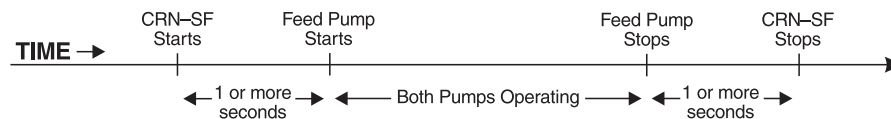

# Starting the Pump the First Time

## Priming

To prime the pump in a closed system or an open system where the water source is above the pump, close the pump isolation valve(s) and open the priming plug on the pump head. See Figures 5A and 5B. Gradually open the isolation valve in the suction line until a steady stream of airless water runs out the priming port. Close the plug and securely tighten. Completely open the isolation valves.

In open systems where the water level is below the pump inlet, the suction pipe and pump must be filled and vented of air before starting the pump. Close the discharge isolation valve and remove the priming plug. Pour water through the priming hole until the suction pipe and pump are completely filled with water. If the suction pipe does not slope downward from the pump toward the water level, the air must be purged while being filled. Replace the priming plug and securely tighten.

1. Switch power off.
2. Check to make sure the pump has been filled and vented.
3. Remove the coupling guard and rotate the pump shaft by hand to be certain it turns freely.
4. Verify that the electrical connections are in accordance with the wiring diagram on the motor.
5. Switch the power on and observe the direction of rotation. When viewed from the top, the pump should rotate counter-clockwise (clockwise for CRN-SF).
6. To reverse the direction of rotation, first switch OFF the supply power.
7. On three-phase motors, interchange any two power leads at the load side of the starter. On single-phase motors, see connection diagram on nameplate. Change wiring as required.
8. Switch on the power and again check for proper motor rotation. Once rotation has been verified, switch off power again. Do not attempt to reinstall the coupling guards with the motor energized. Replace the coupling guard if the rotation is correct. After guards are in place the power can be reapplied.



**NOTE: Motors should not be run unloaded or uncoupled from the pump at any time; damage to the motor bearings will occur.**

**REMINDER: Do not start the pump before priming or venting the pump. Never operate the pump dry.**

## Operating Parameters

CR multi-stage centrifugal pumps installed in accordance with these instructions and sized for correct performance will operate efficiently and provide years of service. The pumps are water-lubricated and do not require any external lubrication or inspection. The motors will require periodic lubrication as noted in the following Maintenance Section.

Under no circumstances should the pump be operated for any prolonged periods of time without flow through the pump. This can result in motor and pump damage due to overheating. A properly sized relief valve should be installed to allow sufficient water to circulate through the pump to provide adequate cooling and lubrication of the pump bearings and seals.

## Pump cycling

Pump cycling should be checked to ensure the pump is not starting more than:

- 20 times per hour on 1/3 to 5 HP models
- 15 times per hour on 7 1/2 to 15 HP models
- 10 times per hour on 20 to 60 HP models

Rapid cycling is a major cause of premature motor failure due to increased heat build-up in the motor. If necessary, adjust controls to reduce the frequency of starts and stops.

## Boiler-feed installations

If the pump is being used as a boiler-feed pump, make sure the pump is capable of supplying sufficient water throughout its entire evaporation and pressure ranges. Where modulating control valves are used, a bypass around the pump must be installed to ensure pump lubrication (see "Minimum Continuous Duty Flow Rates").

## Freeze Protection

If the pump is installed in an area where freezing could occur, the pump and system should be drained during freezing temperatures to avoid damage. To drain the pump, close the isolation valves, remove the priming plug and drain plug at the base of the pump. Do not replace the plugs until the pump is to be used again. Always replace the drain plug with the original or exact replacement. **Do not** replace with a standard plug. Internal recirculation will occur, reducing the output pressure and flow.

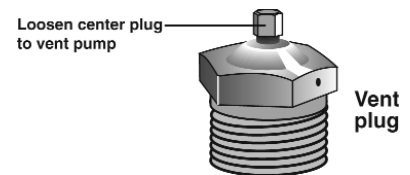
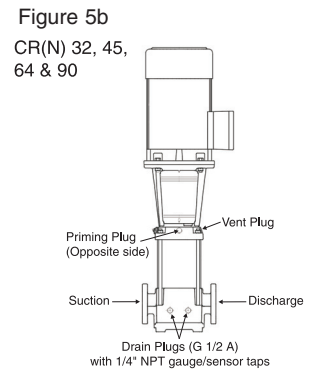
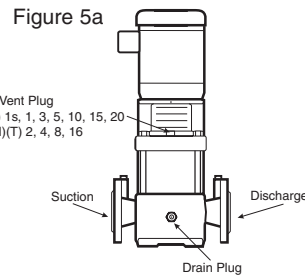

## Motor Inspection

Inspect the motor at regular intervals, approximately every 500 hours of operation or every three months, whichever occurs first. Keep the motor clean and the ventilation openings clear. The following steps should be performed at each inspection:

### WARNING:



**DO NOT TOUCH ELECTRICAL CONNECTIONS BEFORE YOU FIRST ENSURE THAT POWER HAS BEEN DISCONNECTED. ELECTRICAL SHOCK CAN CAUSE SERIOUS OR FATAL INJURY. ONLY QUALIFIED PERSONNEL SHOULD ATTEMPT INSTALLATION, OPERATION, AND MAINTENANCE OF THIS EQUIPMENT.**

1. Check that the motor is clean. Check that the interior and exterior of the motor is free of dirt, oil, grease, water, etc. Oily vapor, paper, pulp, textile lint, etc. can accumulate and block motor ventilation. If the motor is not properly ventilated, overheating can occur and cause early motor failure.
2. Use an Ohmmeter ("Megger") periodically to ensure that the integrity of the winding insulation has been maintained. Record the Ohmmeter readings. Immediately investigate any significant drop in insulation resistance.
3. Check all electrical connectors to be sure that they are tight.

## Motor Lubrication

Electric motors are pre-lubricated at the factory and do not require additional lubrication at start-up. Motors without external grease fittings have sealed bearings that cannot be re-lubricated. Motors with grease fittings should **only** be lubricated with approved types of grease. Do not **over-grease** the bearings. Over greasing will cause increased bearing heat and can result in bearing/motor failure. Do not mix petroleum grease and silicon grease in motor bearings.

Bearing grease will lose its lubricating ability over time, not suddenly. The lubricating ability of a grease (over time) depends primarily on the type of grease, the size of the bearings, the speed at which the bearings operate and the severity of the operating conditions. Good results can be obtained if the following recommendations are used in your maintenance program. It should also be noted that pumps with more stages, pumps running to the left of the performance curve, certain pump ranges may have higher thrust loads. Pumps with high thrust loads should be greased according to the next service interval level.

Severity of Service	Ambient Temperature (Maximum)	Environment	Approved Types of Grease
Standard	+104°F (+40°C)	Clean, little corrosion	See motor nameplate for grease type or compatible equivalent type of grease
Severe	+122°F (+50°C)	Moderate dirt, corrosion	
Extreme	>+122°F (+50°C) or Class H insulation	Severe dirt, abrasive dust, corrosion	

If pump is fitted with a bearing flange that requires grease, see the stickers on either the bearing flange or coupling guards for proper grease type and greasing schedule.

## Motor Lubrication Schedule

NEMA/(IEC) Frame Size	Standard Service Interval	Severe Service Interval	Extreme Service Interval	Weight of Grease to Add Oz./(Grams)	Volume of Grease to Add In <sup>3</sup> /(Teaspoons)
Up through 210 (132)	5500 hrs.	2750 hrs.	550 hrs.	0.30 (8.4)	0.6 (2)
Over 210 through 280 (180)	3600 hrs.	1800 hrs.	360 hrs.	0.61 (17.4)*	1.2 (3.9)*
Over 280 up through 360 (225)	2200 hrs.	1100 hrs.	220 hrs.	0.81 (23.1)*	1.5 (5.2)*
Over 360 (225)	2200 hrs.	1100 hrs.	220 hrs.	2.12 (60.0)*	4.1 (13.4)*

\*The grease outlet plug **MUST** be removed before adding new grease.

## Procedure

### CAUTION:



**TO AVOID DAMAGE TO MOTOR BEARINGS, GREASE MUST BE KEPT FREE OF DIRT. FOR AN EXTREMELY DIRTY ENVIRONMENT, CONTACT YOUR BALDOR DISTRIBUTOR OR AN AUTHORIZED BALDOR SERVICE CENTER FOR ADDITIONAL INFORMATION.**

1. Clean all grease fittings. If the motor does not have grease fittings, the bearing is sealed and cannot be greased externally.
2. If the motor is equipped with a grease outlet plug, remove it. This will allow the old grease to be displaced by the new grease.
3. If the motor is stopped, add the recommended amount of grease. If the motor is to be greased while running, a slightly greater quantity of grease will have to be added.

**NOTE: If new grease does not appear at the shaft hole or grease outlet plug, the outlet passage may be blocked. At the next service interval the bearings must be repacked.**

Add grease **SLOWLY** until new grease appears at the shaft hole in the endplate or grease outlet plug. Never add more than 1-1/2 times the amount of grease shown in the lubrication schedule.

4. For motors equipped with a grease outlet plug, let the motor run for 20 minutes before replacing the plug.

# Preventative Maintenance

At regular intervals depending on the conditions and time of operation, the following checks should be made:

1. Pump meets required performance and is operating smoothly and quietly.
2. There are no leaks, particularly at the shaft seal.
3. The motor is not overheating.
4. Remove and clean all strainers or filters in the system.
5. Verify the tripping of the motor overload protection.
6. Check the operation of all controls. Check unit control cycling twice and adjust, if necessary.
7. If the pump is not operated for unusually long periods, the unit should be maintained in accordance with these instructions. In addition, if the pump is not drained, the pump shaft should be manually rotated or run for short periods of time at monthly intervals.
8. To extend the pump life in severe duty applications, consider performing one of the following actions:
  - Drain the pump after each use.
  - Flush the pump, through system, with water or other fluid that is compatible with the pump materials and process liquid.
  - Disassemble the pump liquid components and thoroughly rinse or wash them with water or other fluid that is compatible with the pump materials and process liquid.

If the pump fails to operate or there is a loss of performance, refer to the Troubleshooting Section on pages 13-14.

# Motor Replacement

If the motor is damaged due to bearing failure, burning or electrical failure, the following instructions detail how to remove the motor for replacement. It must be emphasized that motors used on CR pumps are specifically selected to our rigid specifications. Replacement motors must be of the same frame size, should be equipped with the same or better bearings and have the same service factor. Failure to follow these recommendations may result in premature motor failure.

## Disassembly

1. Turn off and lock out power supply. The power supply wiring can not be safely disconnected from the motor wires.
2. Remove the coupling guards.
3. Using the proper metric Allen wrench, loosen the four cap screws in the coupling. Completely remove coupling halves. On CR1s-CR20, the shaft pin can be left in the pump shaft. CR(N)32, 45, 64 and 90 do not have a shaft pin.

**CR 1s, 1, 3, 5, 10, 15, and 20: do not loosen the three shaft seal securing allen screws.**

4. With the correct size wrench, loosen and remove the four bolts which hold the motor to the pump end.
5. Lift the motor straight up until the shaft has cleared the motor stool.

## Assembly

1. Remove key from motor shaft, if present, and discard.
2. Thoroughly clean the surfaces of the motor and pump end mounting flange. The motor and shaft must be clean of all oil/grease and other contaminants where the coupling attaches. Set the motor on the pump end.
3. Place the terminal box in the desired position by rotating the motor.
4. Insert the mounting bolts, then diagonally and evenly tighten. For 3/8" bolts, torque to 17 ft.-lbs., for 1/2" bolts torque to 30 ft.-lbs., and for 5/8" bolts torque to 59 ft.-lbs.
5. **CR 1s, 1, 3, and 5:**  
Insert shaft pin into shaft hole. Reinstall the coupling halves onto shaft and shaft pin. Reinstall the coupling screws and leave loose. Check that the gaps on either side of the coupling are even, and that the motor shaft keyway is centered in the coupling half, as shown in Figure 6a, page 11. Tighten the screws to the correct torque.

**CR 10, 15 and 20:**

Insert shaft pin into shaft hole. Insert plastic shaft seal spacer beneath shaft seal collar. Reinstall the coupling halves onto shaft and shaft pin. Reinstall the coupling screws and leave loose. Check that the gaps on either side of the coupling are even and that the motor shaft keyway is centered in the coupling half, as shown in Figure 6a, page 11. Tighten the screws to the correct torque. Remove plastic shaft seal spacer and hang it on inside of coupling guard.

**CR 2, 4, 8 and 16:**

Reinstall coupling halves. Make sure the shaft pin is located in the pump shaft. Put the cap screws loosely back into the coupling halves. Using a large screwdriver, raise the pump shaft by placing the tip of the screwdriver under the coupling and carefully elevating the coupling to its highest point (see Figure 6). Note: the shaft can only be raised approximately 0.20 inches (5mm). Now lower the shaft halfway back down the distance you just raised it and tighten the coupling screws (finger tight) while keeping the coupling separation equal on both sides. When the screws are tight enough to keep the couplings in place, then torque the screws evenly in a criss-cross pattern.

Figure 6  
CR(X)(N)(T) 8, 16 & CRT 2, 4

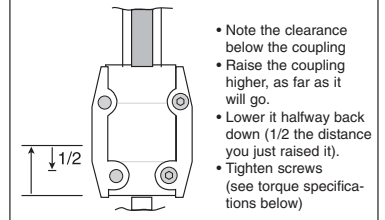
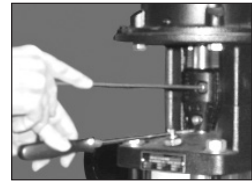

**CR(N) 32, 45, 64 & CR90:**

Place the plastic adjustment fork under the cartridge seal collar (see Figure 7).

Fit the coupling on the shaft so that the top of the pump shaft is flush with the bottom of the clearance chamber in the coupling (see Figure 8).

Lubricate the coupling screws with an anti-seize and lubricating compound. Tighten the coupling screws (finger tight) while keeping the coupling separation equal on both sides and the motor shaft keyway centered in the coupling half as shown in Figure 6a. When the screws are tight enough to keep the couplings in place, then torque the screws evenly in a crisscross pattern.

Torque coupling screws to 62 ft.-lbs. Remove the adjustment fork from under the cartridge seal collar and replace it to the storage location (see Figure 9).

6. Check to see that the gaps between the coupling halves are equal. Loosen and readjust, if necessary.
7. Be certain the pump shaft can be rotated by hand. If the shaft cannot be rotated or it binds, disassemble and check for misalignment.
8. Prime the pump.
9. Follow the wiring diagram on the motor label for the correct motor wiring combination which matches your supply voltage. Once this has been confirmed, reconnect the power supply wiring to the motor.
10. Check the direction of rotation, by bump-starting the motor. Rotation must be left to right (counter-clockwise) when looking directly at the coupling.
11. Shut off the power, then re-install the coupling guards. After the coupling guards have been installed the power can be turned back on.

Torque Specifications CR(I)(N) 1s, 1, 3, 5, 10, 15, and 20 CR(N)(X)(T) 2, 4, 8, and 16	
Coupling Bolt Size	Min. Torque Specifications
M6	10 ft.-lbs.
M8	23 ft.-lbs.
M10	46 ft.-lbs.

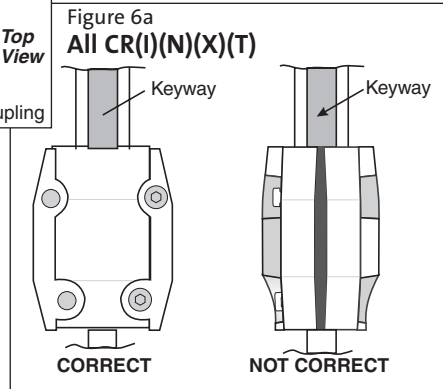
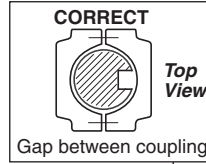

**Parts List**

For each CR pump model Grundfos offers an extensive **Parts List** and diagram of part used in that pump and is recommended to have on hand for future maintenance. In addition, the listings also provide information about prepackaged **Service Kits** for those pump components most likely to exhibit wear over time, as well as the complete Impeller Stack needed to replace the "guts" of each model. These Parts Lists are available separately from the Grundfos literature warehouse or as a set with extensive service instructions in the Grundfos CR **Service Manuals** (for a small charge).



Left, prepackaged impeller stacks ready for immediate installation; right, prepackaged flange kits.

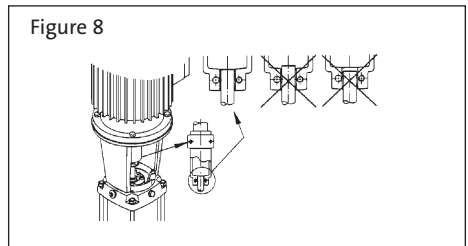
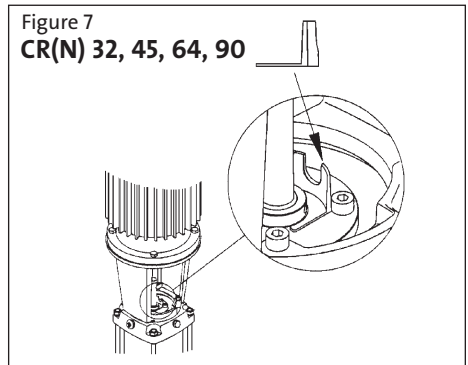

**NOTE:** To avoid damaging the coupling halves, ensure that no portion of the keyway on the motor shaft lies within the gap between the two coupling halves.

**Spare Parts**

Grundfos offers an extensive list of spare parts. For a current list of these parts, refer to: "All Product Spare Parts/Service Kits" Price List, Form # L-SK-SL-002.

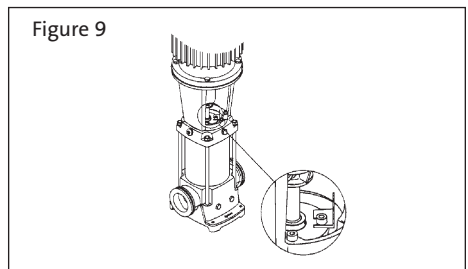

**WARNING:**



WHEN WORKING WITH ELECTRICAL CIRCUITS, USE CAUTION TO AVOID ELECTRICAL SHOCK. IT IS RECOMMENDED THAT RUBBER GLOVES AND BOOTS BE WORN, AND METAL TERMINAL BOXES AND MOTORS ARE GROUNDED BEFORE ANY WORK IS DONE. FOR YOUR PROTECTION, ALWAYS DISCONNECT THE PUMP FROM ITS POWER BEFORE HANDLING.

**Preliminary tests**

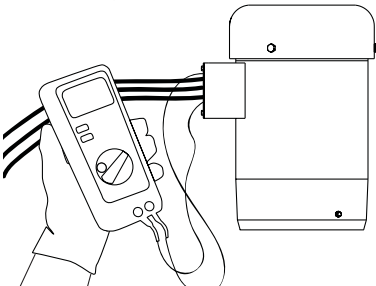
<p><b>Supply voltage</b></p> 	<p><b>How to measure</b></p> <p>Use a voltmeter, (set to the proper scale) measure the voltage at the pump terminal box or starter.</p> <p>On single-phase units, measure between power leads L1 and L2 (or L1 and N for 115 volt units). On three-phase units, measure between:</p> <ul style="list-style-type: none"><li>• Power leads L1 and L2</li><li>• Power leads L2 and L3</li><li>• Power leads L3 and L1</li></ul>	<p><b>What it means</b></p> <p>When the motor is under load, the voltage should be within <math>\pm 10\%</math> of the nameplate voltage. Larger voltage variation may cause winding damage.</p> <p>Large variations in the voltage indicate a poor electrical supply and the pump should not be operated until these variations have been corrected.</p> <p>If the voltage constantly remains high or low, the motor should be changed to the correct supply voltage.</p>
--	--	--

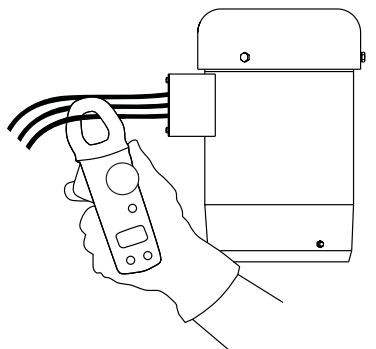
<p><b>Current measurement</b></p> 	<p><b>How to Measure</b></p> <p>Use an ammeter, (set on the proper scale) to measure the current on each power lead at the terminal box or starter. See the motor nameplate for amp draw information.</p> <p>Current should be measured when the pump is operating at constant discharge pressure.</p>	<p><b>What it Means</b></p> <p>If the amp draw exceeds the listed service factor amps (SFA) or if the current imbalance is greater than 5% between each leg on three-phase units, check the following:</p> <ol style="list-style-type: none"><li>1. Burned contacts on motor starter.</li><li>2. Loose terminals in starter or terminal box or possible wire defect.</li><li>3. Too high or too low supply voltage.</li><li>4. Motor windings are shorted or grounded. Check winding and insulation resistances.</li><li>5. Pump is damaged causing a motor overload.</li></ol>
--	--	---

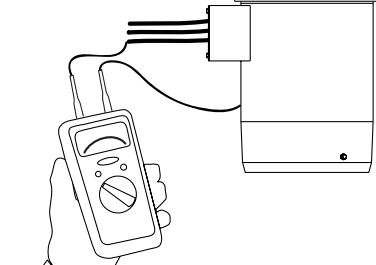
<p><b>Insulation Resistance</b></p> 	<p><b>How to Measure</b></p> <p>Turn off power and disconnect the supply power leads in the pump terminal box. Using an ohm or mega ohm meter, set the scale selector to Rx 100K and zero adjust the meter.</p> <p>Measure and record the resistance between each of the terminals and ground.</p>	<p><b>What it Means</b></p> <p>Motors of all HP, voltage, phase and cycle duties have the same value of insulation resistance. Resistance values for new motors must exceed 1,000,000 ohms. If they do not, motor should be repaired or replaced.</p>
---	--	---

## Diagnosing specific problems

Problem	Possible cause	Remedy
<b>The pump does not run</b>	<ol style="list-style-type: none"> <li>1. No power at motor.</li> <li>2. Fuses are blown or circuit breakers are tripped.</li> <li>3. Motor starter overloads are burned or have tripped out.</li> <li>4. Starter does not energize.</li> <li>5. Defective controls.</li> <li>6. Motor is defective.</li> <li>7. Defective capacitor. (Single-phase motors)</li> <li>8. Pump is bound.</li> </ol>	<p>Check for voltage at motor terminal box. If no voltage at motor, check feeder panel for tripped circuits and reset circuit.</p> <p>Turn off power and remove fuses. Check for continuity with ohmmeter. Replace blown fuses or reset circuit breaker. If new fuses blow or circuit breaker trips, the electrical installation, motor and wires must be checked.</p> <p>Check for voltage on line and load side of starter. Replace burned heaters or reset. Inspect starter for other damage. If heater trips again, check the supply voltage and starter holding coil.</p> <p>Energize control circuit and check for voltage at the holding coil. If no voltage, check control circuit fuses. If voltage, check holding coil for shorts. Replace bad coil.</p> <p>Check all safety and pressure switches for operation. Inspect contacts in control devices. Replace worn or defective parts or controls.</p> <p>Turn off power and disconnect wiring. Measure the lead to lead resistances with ohmmeter (RX-1). Measure lead to ground values with ohmmeter (RX-100K). Record measured values. If an open or grounded winding is found, remove motor and repair or replace.</p> <p>Turn off power and discharge capacitor. Check with ohmmeter (RX-100K). When the meter is connected to the capacitor, the needle should jump towards 0 ohms and slowly drift back to infinity (<math>\infty</math>). Replace if defective.</p> <p>Turn off power and manually rotate pump shaft. If shaft does not rotate easily, check coupling setting and adjust as necessary. If shaft rotation is still tight, remove pump and inspect. Disassemble and repair.</p>
<b>The pump runs but at reduced capacity or does not deliver water</b>	<ol style="list-style-type: none"> <li>1. Wrong rotation</li> <li>2. Pump is not primed or is airbound.</li> <li>3. Strainers, check or foot valves are clogged.</li> <li>4. Suction lift too large.</li> <li>5. Suction and/or discharge piping leaks.</li> <li>6. Pump worn.</li> <li>7. Pump impeller or guide vane is clogged.</li> </ol>	<p>Check wiring for proper connections. Correct wiring.</p> <p>Turn pump off, close isolation valve(s), remove priming plug. Check fluid level. Refill the pump, replace plug and start the pump. Long suction lines must be filled before starting the pump.</p> <p>Remove strainer, screen or valve and inspect. Clean and replace. Reprime pump.</p> <p>Install compound pressure gauge at the suction side of the pump. Start pump and compare reading to performance data. Reduce suction lift by lowering pump, increase suction line size or removing high friction loss devices.</p> <p>Pump runs backwards when turned off. Air in suction pipe. Suction pipe, valves and fittings must be airtight. Repair any leaks and retighten all loose fittings.</p> <p>Install pressure gauge, start pump, gradually close the discharge valve and read pressure at shutoff. Convert measured pressure (in PSI) to head (in feet): (Measured PSI x 2.31 ft./PSI = _____ ft.). Refer to the specific pump curve for shutoff head for that pump model. If head is close to curve, pump is probably OK. If not, remove pump and inspect.</p> <p>Disassemble and inspect pump passageways. Remove any foreign materials found.</p>

## Diagnosing specific problems

Problem	Possible cause	Remedy
<b>The pump runs but at reduced capacity or does not deliver water</b> (continued)	8. Incorrect drain plug installed. 9. Improper coupling setting.	If the proper drain plug is replaced with a standard plug, water will recirculate internally. Replace with proper plug. Check/reset the coupling, see page 10.
<b>Pump cycles too much</b>	1. Pressure switch is not properly adjusted or is defective. 2. Level control is not properly set or is defective. 3. Insufficient air charging or leaking tank or piping. 4. Tank is too small. 5. Pump is oversized.	Check pressure setting on switch and operation. Check voltage across closed contacts. Readjust switch or replace if defective. Check setting and operation. Readjust setting (refer to level control manufacturer's data). Replace if defective. Pump air into tank or diaphragm chamber. Check diaphragm for leak. Check tank and piping for leaks with soap and water solution. Check air to water volume. Repair as necessary. Check tank size and air volume in tank. Tank volume should be approximately 10 gallons for each gpm of pump capacity. The normal air volume is 2/3 of the total tank volume at the pump cut-in pressure. Replace tank with one of correct size. Install pressure gauges on or near pump suction and discharge ports. Start and run pump under normal conditions, record gauge readings. Convert PSI to feet (Measured PSI x 2.31 ft./PSI = _____ ft.) Refer to the specific pump curve for that model, ensure that total head is sufficient to limit pump delivery within its design flow range. Throttle pump discharge flow if necessary.
<b>Fuses blow or circuit breakers or overload relays trip</b>	1. Low voltage. 2. Motor overloads are set too low. 3. Three-phase current is imbalanced. 4. Motor is shorted or grounded. 5. Wiring or connections are faulty. 6. Pump is bound. 7. Defective capacitor (single-phase motors). 8. Motor overloads at higher ambient temperature than motor.	Check voltage at starter panel and motor. If voltage varies more than ±10%, contact power company. Check wire sizing. Cycle pump and measure amperage. Increase heater size or adjust trip setting to a maximum of motor nameplate (full load) current. Check current draw on each lead to the motor. Must be within ±5%. If not, check motor and wiring. Rotating all leads may eliminate this problem. Turn off power and disconnect wiring. Measure the lead-to-lead resistance with an ohmmeter (RX-1). Measure lead-to-ground values with an ohmmeter (RX-100K) or a megaohm meter. Record values. If an open or grounded winding is found, remove the motor, repair and/or replace. Check proper wiring and loose terminals. Tighten loose terminals. Replace damaged wire. Turn off power and manually rotate pump shaft. If shaft does not rotate easily, check coupling setting and adjust as necessary. If shaft rotation is still tight, remove pump and inspect. Disassemble and repair. Turn off power and discharge capacitor. Check with ohmmeter (RX-100K). When the meter is connected to the capacitor, the needle should jump towards 0 ohms and slowly drift back to infinity (∞). Replace if defective. Use a thermometer to check the ambient temperature near the overloads and motor. Record these values. If ambient temperature at motor is lower than at overloads, especially where temperature at overloads is above +104°F (+40°C), ambient-compensated heaters should replace standard heaters.

### Three Phase Motors

Below is a worksheet for calculating current unbalance on a three-phase hookup and selecting the proper wiring. Use the calculations in the left-hand column as a guide.

EXPLANATION & EXAMPLES	
<p>Here is an example of current readings at maximum pump loads on each leg of a three-wire hookup. You must make calculations for all three hookups.</p> <p>To begin, add up all three readings for hookup number 1, 2, and 3.</p>	<p><b>Hookup 1</b></p> <p>T1 = 51 Amps T2 = 46 Amps T3 = 53 Amps</p> <hr/> <p>TOTAL = 150 Amps</p>
<p>Divide the total by three to obtain the average.</p>	<p><b>Hookup 1</b></p> <p>50 Amps</p> $\begin{array}{r} 50 \text{ Amps} \\ 3 \overline{)150 \text{ Amps}} \end{array}$
<p>Calculate the greatest current difference from the average.</p>	<p><b>Hookup 1</b></p> <p>50 Amps - 46 Amps</p> <hr/> <p>4 Amps</p>
<p>Divide this difference by the average to obtain the percentage of unbalance.</p> <p>In this case, the current unbalance for hookup number 1 is 8%.</p>	<p><b>Hookup 1</b></p> <p>.08 or 8%</p> $\begin{array}{r} .08 \text{ or } 8\% \\ 50 \overline{)4.00 \text{ Amps}} \end{array}$

FIGURE HERE		
<p><b>Hookup 1</b></p> <p>L<sub>1</sub> to T<sub>1</sub> = ___ Amps L<sub>2</sub> to T<sub>2</sub> = ___ Amps L<sub>3</sub> to T<sub>3</sub> = ___ Amps</p> <hr/> <p>TOTAL = ___ Amps</p>	<p><b>Hookup 2</b></p> <p>L<sub>1</sub> to T<sub>3</sub> = ___ Amps L<sub>2</sub> to T<sub>1</sub> = ___ Amps L<sub>3</sub> to T<sub>2</sub> = ___ Amps</p> <hr/> <p>TOTAL = ___ Amps</p>	<p><b>Hookup 3</b></p> <p>L<sub>1</sub> to T<sub>2</sub> = ___ Amps L<sub>2</sub> to T<sub>3</sub> = ___ Amps L<sub>3</sub> to T<sub>1</sub> = ___ Amps</p> <hr/> <p>TOTAL = ___ Amps</p>
<p><b>Hookup 1</b></p> <p>___ Amps</p> $3 \overline{) \text{ ___ Amps}}$	<p><b>Hookup 2</b></p> <p>___ Amps</p> $3 \overline{) \text{ ___ Amps}}$	<p><b>Hookup 3</b></p> <p>___ Amps</p> $3 \overline{) \text{ ___ Amps}}$
<p><b>Hookup 1</b></p> <p>___ Amps - ___ Amps</p> <hr/> <p>___ Amps</p>	<p><b>Hookup 2</b></p> <p>___ Amps - ___ Amps</p> <hr/> <p>___ Amps</p>	<p><b>Hookup 3</b></p> <p>___ Amps - ___ Amps</p> <hr/> <p>___ Amps</p>
<p><b>Hookup 1</b></p> <p>___ or ___ %</p> $\begin{array}{r} \text{___ or ___ \%} \\ \text{___} \overline{) \text{ ___ Amps}} \end{array}$	<p><b>Hookup 2</b></p> <p>___ or ___ %</p> $\begin{array}{r} \text{___ or ___ \%} \\ \text{___} \overline{) \text{ ___ Amps}} \end{array}$	<p><b>Hookup 3</b></p> <p>___ or ___ %</p> $\begin{array}{r} \text{___ or ___ \%} \\ \text{___} \overline{) \text{ ___ Amps}} \end{array}$

## LIMITED WARRANTY

Products manufactured by GRUNDFOS PUMPS CORPORATION (GRUNDFOS) are warranted to the original user only to be free of defects in material and workmanship for a period of 24 months from date of installation, but not more than 30 months from date of manufacture. GRUNDFOS' liability under this warranty shall be limited to repairing or replacing at GRUNDFOS' option, without charge, F.O.B. GRUNDFOS' factory or authorized service station, any product of GRUNDFOS' manufacture. GRUNDFOS will not be liable for any costs of removal, installation, transportation, or any other charges which may arise in connection with a warranty claim. Products which are sold but not manufactured by GRUNDFOS are subject to the warranty provided by the manufacturer of said products and not by GRUNDFOS' warranty. GRUNDFOS will not be liable for damage or wear to products caused by abnormal operating conditions, accident, abuse, misuse, unauthorized alteration or repair, or if the product was not installed in accordance with GRUNDFOS' printed installation and operating instructions.

To obtain service under this warranty, the defective product must be returned to the distributor or dealer of GRUNDFOS' products from which it was purchased together with proof of purchase and installation date, failure date, and supporting installation data. Unless otherwise provided, the distributor or dealer will contact GRUNDFOS or an authorized service station for instructions. Any defective product to be returned to GRUNDFOS or a service station must be sent freight prepaid; documentation supporting the warranty claim and/or a Return Material Authorization must be included if so instructed.

GRUNDFOS WILL NOT BE LIABLE FOR ANY INCIDENTAL OR CONSEQUENTIAL DAMAGES, LOSSES, OR EXPENSES ARISING FROM INSTALLATION, USE, OR ANY OTHER CAUSES. THERE ARE NO EXPRESS OR IMPLIED WARRANTIES, INCLUDING MERCHANTABILITY OR FITNESS FOR A PARTICULAR PURPOSE, WHICH EXTEND BEYOND THOSE WARRANTIES DESCRIBED OR REFERRED TO ABOVE.

Some jurisdictions do not allow the exclusion or limitation of incidental or consequential damages and some jurisdictions do not allow limitations on how long implied warranties may last. Therefore, the above limitations or exclusions may not apply to you. This warranty gives you specific legal rights and you may also have other rights which vary from jurisdiction to jurisdiction.



L-CP-TL-003	Rev. 05/04
Printed in USA	

**Grundfos Pumps Corporation**  
17100 W. 118th Terrace  
Olathe, KS 66061  
Telephone 913 227 3400  
Fax: 913 227 3500

[www.grundfos.com](http://www.grundfos.com)

**Grundfos Canada, Inc.**  
2941 Brighton Road  
Oakville, Ontario L6H 6C9 Canada  
Telephone: 905 829 9533  
Fax: 905 829 9512

**Bombas Grundfos de Mexico, S.A. de C.V.**  
Boulevard TLC #15  
Parque Stiva Aeropuerto  
Apodaca, N.L. 66600 Mexico  
Telephone: 52 81 8144 4000  
Fax: 52 81 8144 4010