

TM02 8330 0405

Dimensional sketches

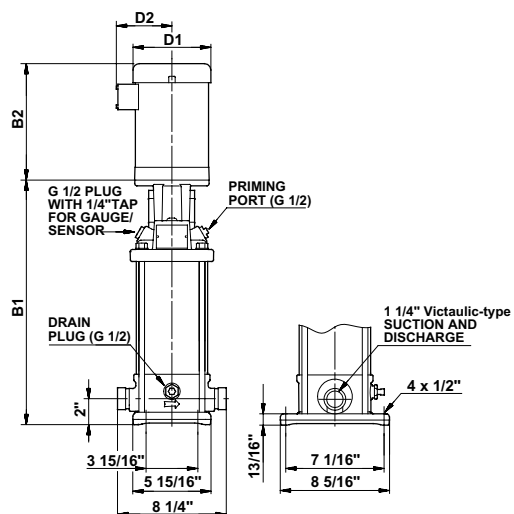

TM02 2149 4604

Dimensions and weight

Pump Type	HP	PH	Voltage	Frame Size	CRT				Ship Wt.	CRTE				
					Dimensions					Ship Wt.	Dimensions			Ship Wt.
					B1	D1	D2	B1+B2			D1	D2	B1+B2	
CRT(E) 2-2	1/2	1	115/208-230	56C	10	6 1/4	5	19 3/8	52	5 5/8	5 5/8	17 3/4	37	
		3	208-230/460	56C	10	6 1/4	5	19 3/8	46	-	-	-	-	
CRT(E) 2-3	3/4	1	115/208-230	56C	10	6 1/4	5	20	55	5 5/8	5 5/8	17 3/4	39	
		3	208-230/460	56C	10	6 1/4	5	19 3/8	48	-	-	-	-	
CRT(E) 2-4	1	1	115/208-230	56C	11 1/2	7 1/4	5 3/4	22 3/4	68	5 5/8	5 5/8	20 3/4	43	
		3	208-230/460	56C	11 1/2	7 1/4	5 3/4	21 3/4	58	7 1/8	6 5/8	22 7/8	68	
CRT 2-5	1 1/2	1	115/208-230	56C	11 1/2	7 1/4	5 3/4	23 1/4	74	-	-	-	-	
		3	208-230/460	56C	11 1/2	7 1/4	5 3/4	22 1/4	62	-	-	-	-	
CRT(E) 2-6	1 1/2	1	115/208-230	56C	12 7/8	7 1/4	5 3/4	24 5/8	76	5 5/8	5 5/8	22 1/8	49	
		3	208-230/460	56C	12 7/8	7 1/4	5 3/4	23 5/8	63	7 1/8	6 5/8	24 1/4	69	
CRT(E) 2-7	2	1	115/208-230	56C	12 7/8	7 1/4	5 3/4	25 1/2	83	-	-	-	-	
		3	208-230/460	56C	12 7/8	7 1/4	5 3/4	24 5/8	71	7 1/8	6 5/8	24 1/4	74	
CRT(E) 2-9	3	1	115/208-230	182TC	16	8 5/8	6 7/8	30 1/2	110	-	-	-	-	
		3	208-230/460	182TC	16	8 5/8	6 7/8	28 1/2	91	7 1/8	6 5/8	28 7/8	84	
CRT 2-11	3	1	115/208-230	182TC	16	8 5/8	6 7/8	30 1/2	111	-	-	-	-	
		3	208-230/460	182TC	16	8 5/8	6 7/8	28 1/2	91	-	-	-	-	
CRT(E) 2-13	3	1	115/208-230	182TC	18 3/4	8 5/8	6 7/8	33 1/4	114	-	-	-	-	
		3	208-230/460	182TC	18 3/4	8 5/8	6 7/8	31 1/4	94	7 1/8	6 5/8	31 5/8	88	
CRT 2-15	5	1	208-230	182TC	18 3/4	10 5/8	7 1/2	34 1/8	144	-	-	-	-	
		3	208-230/460	182TC	18 3/4	8 5/8	6	34 3/4	111	-	-	-	-	
CRT(E) 2-18	5	1	208-230	182TC	21 1/2	10 5/8	7 1/2	36 7/8	150	-	-	-	-	
		3	208-230/460	182TC	21 1/2	8 5/8	6	37 1/2	117	8 3/4	7 1/2	36 3/8	123	