

TM02 8331 0405

Dimensional sketches

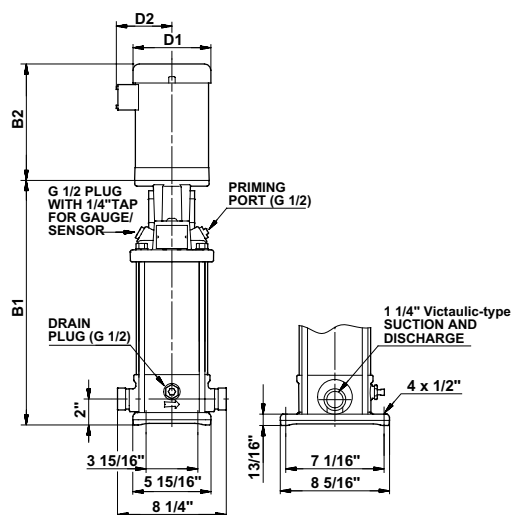

TM02 2149 4604

Dimensions and weight

Pump Type	HP	PH	Voltage	Frame Size	CRT				Ship Wt.	CRTE			Ship Wt.
					Dimensions					D1	D2	B1+B2	
					B1	D1	D2	B1+B2					
CRT(E) 4-1	1/2	1	115/208-230	56C	10 1/8	6 1/4	5	19 1/2	51	5 5/8	5 5/8	17 7/8	36
		3	208-230/460	56C	10 1/8	6 1/4	5	19 1/2	45	-	-	-	-
CRT(E) 4-2	3/4*	1	115/208-230	56C	10 1/8	6 1/4	5	20 1/8	55	5 5/8*	5 5/8*	19 3/8*	40*
		3	208-230/460	56C	10 1/8	6 1/4	5	19 1/2	48	-	-	-	-
CRT(E) 4-3	1 1/2	1	115/208-230	56C	12 1/4	7 1/4	5 3/4	24	73	5 5/8	5 5/8	21 1/2	42
		3	208-230/460	56C	12 1/4	7 1/4	5 3/4	23	61	7 1/8	6 5/8	23 5/8	67
CRT(E) 4-4	1 1/2	1	115/208-230	56C	12 1/4	7 1/4	5 3/4	24	74	5 5/8	5 5/8	21 1/2	48
		3	208-230/460	56C	12 1/4	7 1/4	5 3/4	23	62	7 1/8	6 5/8	23 5/8	68
CRT(E) 4-5	2	1	115/208-230	56C	14 1/2	7 1/4	5 3/4	27 1/8	83	-	-	-	-
		3	208-230/460	56C	14 1/2	7 1/4	5 3/4	26 1/4	71	7 1/8	6 5/8	25 7/8	74
CRT 4-6	3	1	115/208-230	182TC	14 1/2	8 5/8	6 7/8	29	110	-	-	-	-
		3	208-230/460	182TC	14 1/2	8 5/8	6 7/8	27	91	-	-	-	-
CRT 4-7	3	1	115/208-230	182TC	16 5/8	8 5/8	6 7/8	31 1/8	110	-	-	-	-
		3	208-230/460	182TC	16 5/8	8 5/8	6 7/8	29 1/8	91	-	-	-	-
CRT(E) 4-8	3	1	115/208-230	182TC	16 5/8	8 5/8	6 7/8	31 1/8	111	-	-	-	-
		3	208-230/460	182TC	16 5/8	8 5/8	6 7/8	29 1/8	92	7 1/8	6 5/8	29 1/2	85
CRT 4-10	5	1	208-230	182TC	21 1/2	10 5/8	7 1/2	36 7/8	142	-	-	-	-
		3	208-230/460	182TC	21 1/2	8 5/8	6	37 1/2	109	-	-	-	-
CRT(E) 4-12	5	1	208-230	182TC	21 1/2	10 5/8	7 1/2	36 7/8	149	-	-	-	-
		3	208-230/460	182TC	21 1/2	8 5/8	6	37 1/2	116	8 3/4	7 1/2	36 3/8	122
CRT 4-14	7 1/2	1	208-230	213TC	25 3/4	10 1/4	7 1/2	41 1/8	165	-	-	-	-
		3	208-230/460	213TC	25 3/4	10 1/4	8 1/8	41 1/8	134	-	-	-	-
CRT(E) 4-16	7 1/2	1	208-230	213TC	25 3/4	10 1/4	7 1/2	41 1/8	167	-	-	-	-
		3	208-230/460	213TC	25 3/4	10 1/4	8 1/8	41 1/8	136	8 3/4	7 1/2	41 3/8	142

* 1-phase CRTE 4-2 requires 1.0 HP MLE motor.