

Dimensions and Weights

33SV Series 3500 RPM

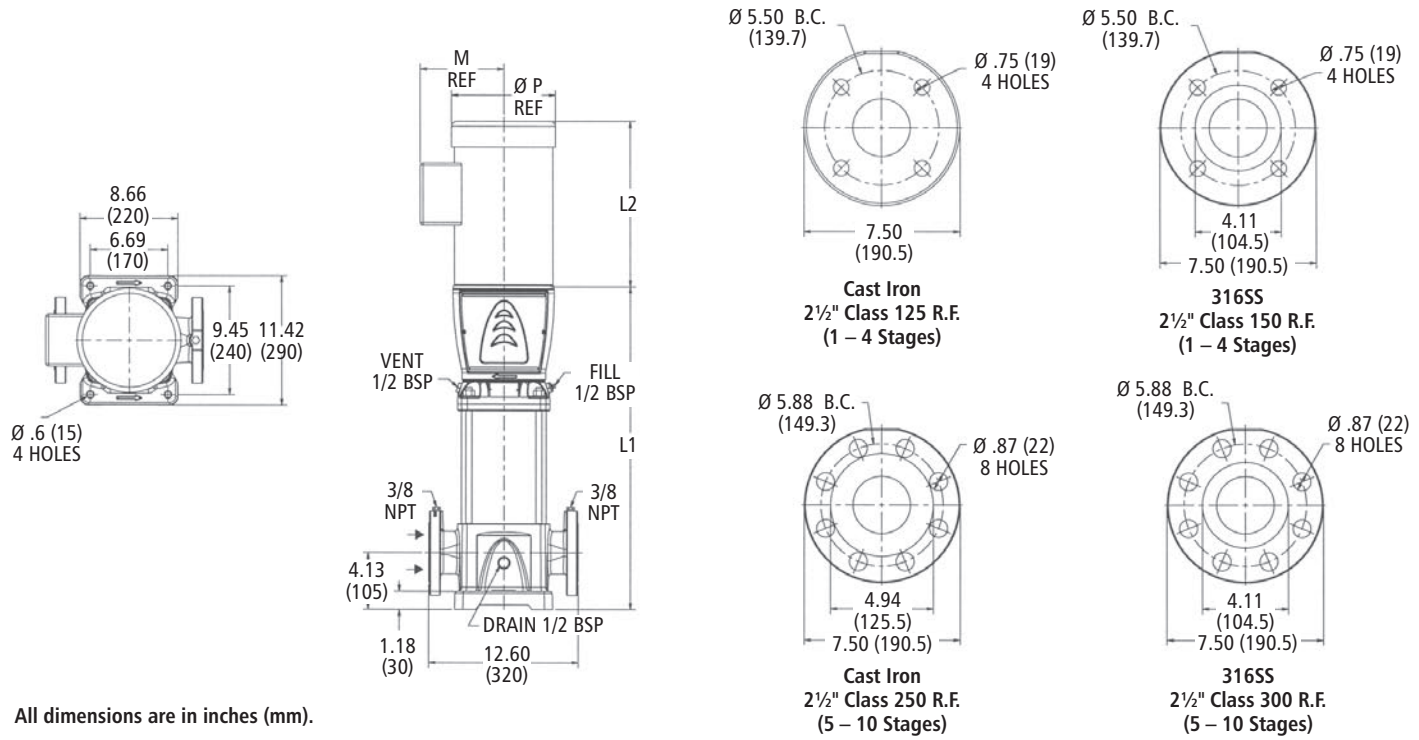

Stage	Frame (1-Phase)		Frame (3-Phase)		HP	L1	L2		M (ref.)	D1		Weights (lb)		
	ODP	TEFC	ODP	TEFC			ODP	TEFC		ODP	TEFC	Liquid End	ODP	TEFC
1/1	182-4TC		182-4TC		5	20.62	13.94	15.44	6.88	8.50	8.50	132	75	85
1					7½									
2/2	213TC		213TC 215TC		10	23.58	15.50	8.06	8.06	10.25	10.25	143	130	151
2/1					2									
3/2	213TC		215TC 254TC		15	26.54	15.56	16.56	9.25	10.19	10.31	152	128	250
3/1					3									
4/2	213TC		254TC 256TC		20	29.50	15.56	16.56	9.25	10.19	10.31	161	220	280
4/1					4									
5/2	213TC		256TC 284TC		25	32.44	18	18	11.63	11.63	11.63	172	240	420
5/1					5									
6/2	213TC		284TC		30	35.40	20.12	20.12	13.12	13.25	15.30	186	325	445
6/1					6									
7/2	213TC		284TC		40	38.35	20.12	20.12	13.12	13.25	15.30	194	328	448
7/1					7									
8/2	213TC		326TSC		50	44.25	22.5	22.5	13.12	13.25	15.30	221	382	592
8/1					8									
9/2	213TC		326TSC		50	47.20	22.5	22.5	13.12	13.25	15.30	229	382	592
9/1					9									
10/2	213TC		326TSC		50	47.20	22.5	22.5	13.12	13.25	15.30	238	382	592
10/1					10									
10	213TC		326TSC		50	47.20	22.5	22.5	13.12	13.25	15.30	249	382	592

33SV Curve 3500 RPM

