

# ZX

## effluent pump

Robust high-quality VORTEX submersible pumps in stainless steel. The proven VORTEX system allows the clearing of dirty water containing suspended solids.



### RANGE OF PERFORMANCE

Capacity up to 106 gpm  
Head up to 36 feet

### LIMITS OF USE

Depth up to 15 ft  
Liquid temperature up to 104°F  
Solid Handling up to 1 1/2"  
Drainage level 1 1/2" from the bottom  
For continuous duty: minimum immersion 9" from pump base

### CONSTRUCTION AND SAFETY STANDARDS

EN 60 335-1      EN 60034-1  
IEC 335-1      IEC 34-1  
CEI 61-150      CEI 2-3



### INSTALLATION AND USE

**ZX PUMPS ARE RECOMMENDED FOR DRAINING WASTE WATER IN THE DOMESTIC SECTOR, FOR CLEARING DIRTY WATER, EVEN CONTAINING SUSPENDED SOLID BODIES WITH DIMENSIONS UP TO Ø 1.5". THEY ARE OUT STANDING IN BOTH THEIR SIMPLICITY OF INSTALLATION AND THEIR RELIABILITY IN FIXED INSTALLATIONS WITH AUTOMATIC OPERATION.**

**GUARANTEE 2 YEAR** subject to our general terms of sale.

### CONSTRUCTION CHARACTERISTICS

- **DELIVERY BODY:** cast iron, with threaded port
- **MOTOR CASING:** stainless steel AISI 304.
- **IMPELLER:** open type, in glas filled technopolymer.
- **MOTOR SHAFT:** stainless steel EN 10088-3 - 1.4104.
- **MECHANICAL SEAL:** ceramic - graphite - NBR.
- **MOTOR:** submersible asynchronous single-phase for continuous duty.
- **ZX:** single-phase 115 and 230 V - 60 Hz with capacitor and thermal overload protector.
- **INSULATION:** class F. • **PROTECTION:** IP 68.

### STANDARD FEATURES:

- **ZX** Float switch.  
Neoprene power cord "H07 RN-F" length 30 feet

### OPTIONS ON REQUEST

- special mechanical seal
- other voltages or frequency 50 Hz



tech.support (954) 474 9090

www.pedrollousa.com

customerservice@pedrollousa.com

CURVES AND PERFORMANCE DATA

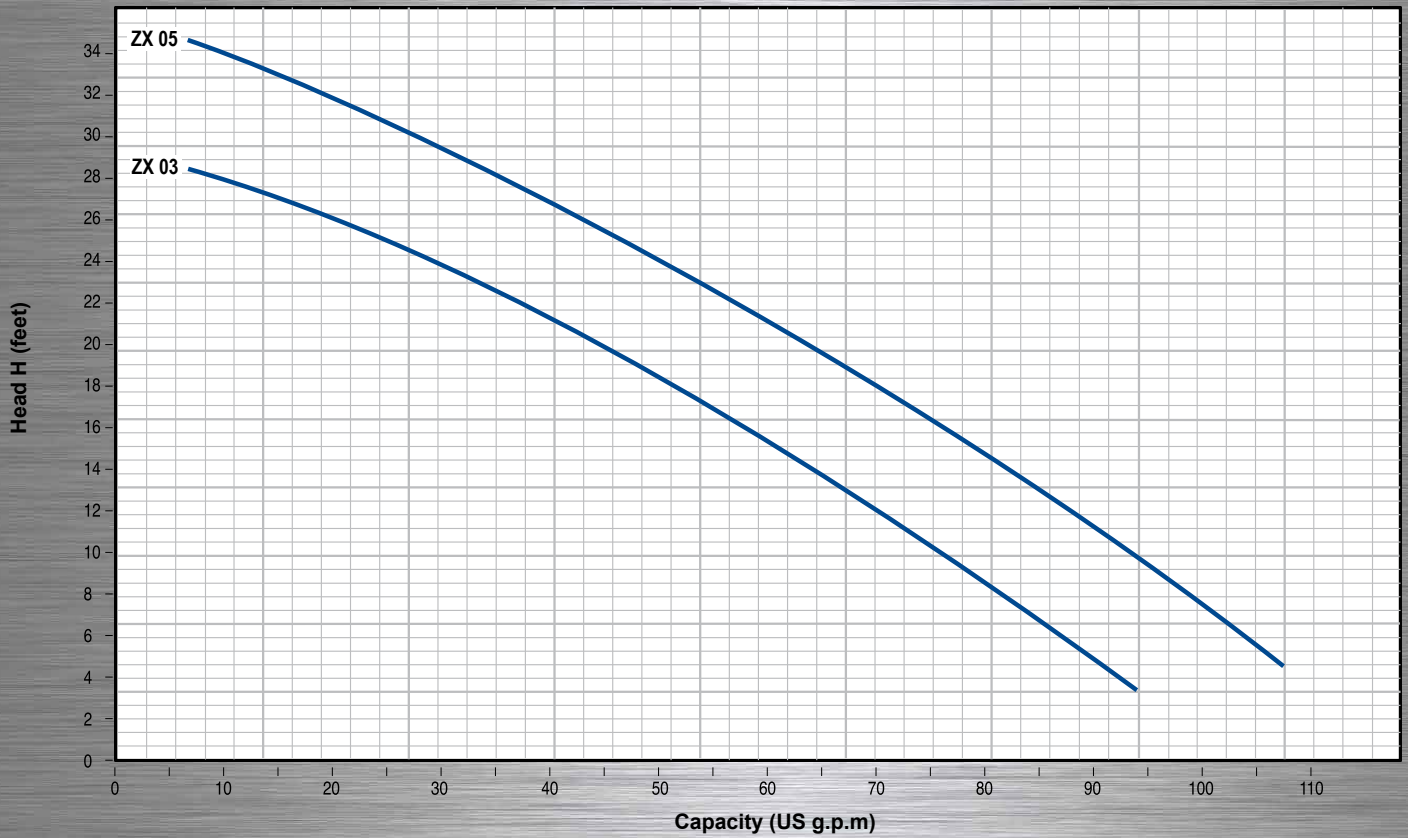

MODEL	HP	CAPACITY GPM	0	7	13	20	26	33	40	53	66	79	93	106
1 PH														
ZX 03	0.33	H. Feet	30	28	27	26	25	23	21	17	13	8	3	
ZX 05	0.50		36	34	33	31	30	28	27	23	19	14	9	5

DIMENSIONS AND WEIGHTS

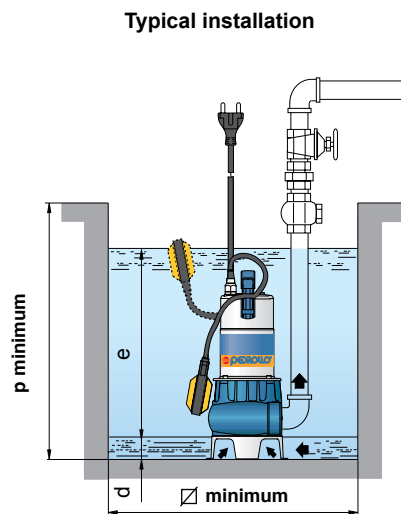
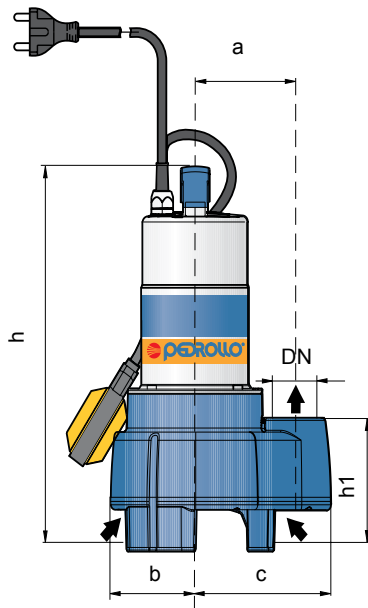

MODEL	DISCH	DIMENSIONS INCHES									LBS
1 PH	DN	a	b	c	h	h1	d	e	p	∅min	1~
ZX 03	1 1/2"	4.33	3.66	5.91	14.65	5.04	1.57	Adjustable	17.72	17.72	23.9
ZX 05											27.4